



**work safely**





**work safely**





Catalogue valid as of 16/10/2023. Please quote name and catalogue number when ordering. The images in the catalogue may differ from the product on sale. The photos may include additional options which are not included in the standard equipment.

Inter Tech reserves the right to change technical parameters and other physical characteristics. Inter Tech reserves the right to make changes to the products without informing the customer. The weights given are approximate and may differ from the actual weight depending on equipment and configuration. The catalogue is for information purposes only and does not constitute a commercial offer within the meaning of Article 543 of the Civil Code. The General Terms and Conditions of Sale (GTS) are available on the Inter Tech website [www.intertech-agro.pl](http://www.intertech-agro.pl).

# Mission



Fusion of passion, knowledge, commitment in an ever-changing world.

# Vision



We are the company that best in agribusiness YESes care of relationships according to individual customer needs.



# Courage



- Boldness and openness
- Determination
- Commitment and passion for common goals

# Development



- Emphasis on innovation
- Development of skills and knowledge
- Searching for better and better solutions, meeting customers by constantly improving quality.

# Partnership



- Human First
- Building lasting relationships
- Commitment

We are intensively developing the sales segment and new products and services. We are adapting our business profile to be fully customer-focused. The values reflect the way Inter Tech wants to achieve its goals. The essence of the Human First partnership is customer focus, building lasting relationships and commitment. We actively increase the potential of new products through the fusion of modern contact channels and compatible services. Development means an emphasis on innovation, development of skills and knowledge and the search for ever better solutions, meeting customers by constantly improving quality. Courage means boldness and openness, determination as well as commitment and passion in achieving common goals. The combination of these values leads to a better understanding of customer expectations, allows us to respond to market challenges and strengthens the Inter Tech Family's corporate culture.

# Inter Tech Family

A fusion of passion, knowledge, commitment in an ever-changing world.

We have nothing to hide. Inter Tech is more than a company.

It is a community where everyone is treated like a family member.

There are few family businesses that build a lasting foundation in international relationships having a significant impact on agricultural development.

Inter Tech Family is the ideal place for ambitious, enthusiastic people looking for inspiration in their development, for whom gaining professional experience is a great motivation for work and a source of satisfaction.



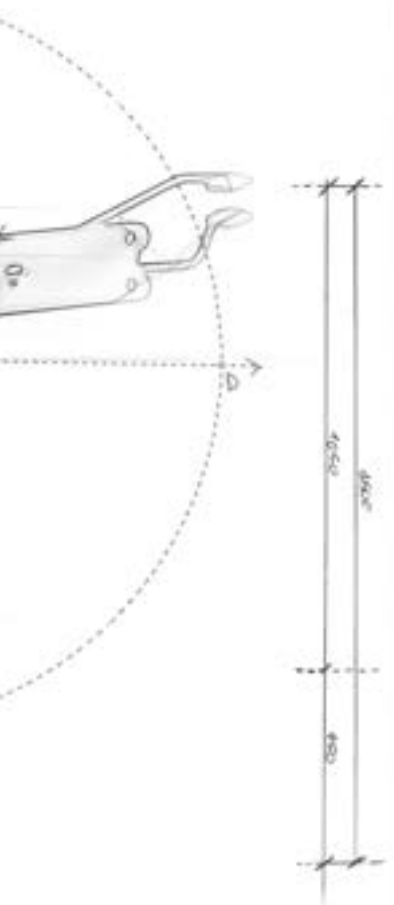

# Loader Line

Quality matters.

Especially when reliable equipment is needed for farm work. Time and efficiency are today's key factors for smooth operation. Following this path, Inter Tech is relentless in its pursuit of perfection.

We create loaders from the highest quality components, constantly seeking new solutions dedicated to the personalized needs of our customers.

# FRONT LOADER

The front loader is an agricultural machine attached to the frame of a farm tractor. The machine is used for loading and unloading transport means of materials such as sand, gravel, mineral fertilizers, lime, manure, beets, potatoes, straw, or hay. The front loader can also be used for transport purposes.

Inter Tech front loaders can be used with most tractors offered on the European market and are applicable in every agricultural enterprise. For all models, there is the possibility of choosing high-class grabs, buckets, forks, and various types of equipment necessary in every farm.

The installed shock absorber effectively reduces shocks, providing a full sense of work comfort. Optimally selected angles of collection and dumping allow for reducing work time and making it more efficient.

The loader can be adapted to any tractor model with power ranging from 15 HP to 220 HP.

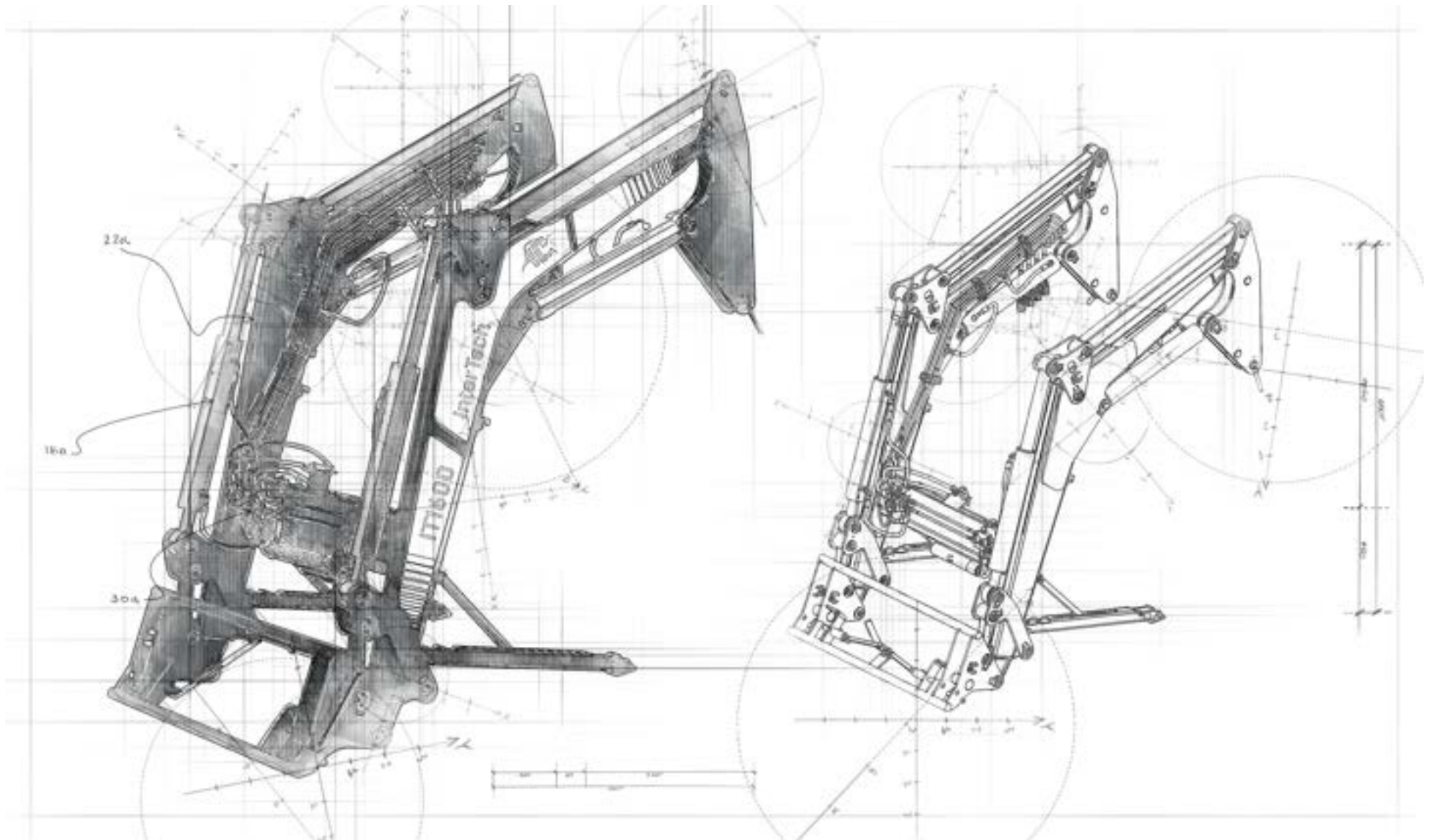

FRONT LOADER

**One tractor - a lot of possibilities**



IT 1800

**Discover GREENPOWER**





# FRONT LOADER

## IT1800



75-150 KM



1800 kg



3650 mm

# FRONT LOADER IT1800

FRONT  
**LOADER**  
line

Model	IT1800
Machine no	L8
Hydraulic cylinder (mm)	80/45/500
Load capacity (kg)	1800
Tractor power (HP)	75 - 150
Weight (kg)	487
Lifting height to the frame rotation axis (mm)	3650
Loading height (mm)	3075
Type of tools connection	EURO or SMS
Type of supports	Support foot
Steerage	Joystick
Type of mounting on the tractor	Bolts
Price per set (€)	●
Price of a loader boom without hydraulics (€)	●
Price of supporting structure and hydraulics (€)	●
Equipment	
Frame EURO or SMS	✓
Self locking frame	✓
3-section hydraulic	✓
Joystick	✓
Color	✓
Piston shock absorber (€)	● ●
Quick connector (€)	○ ●
Electro-hydraulic divider (€)	●
Tilt indicator (€)	●
Hydraulic frame closing (€)	●
4-section (€)	●
Installation at the manufacturer's premises (€)	●
Installation at the dealer's or end customer's premises (€)	●
Service package	● ●



- ✓ Standard equipment
- Optional equipment
- Option not available
- Recommended
- Especially recommended



IT1600

**A lot of power – even more precision**

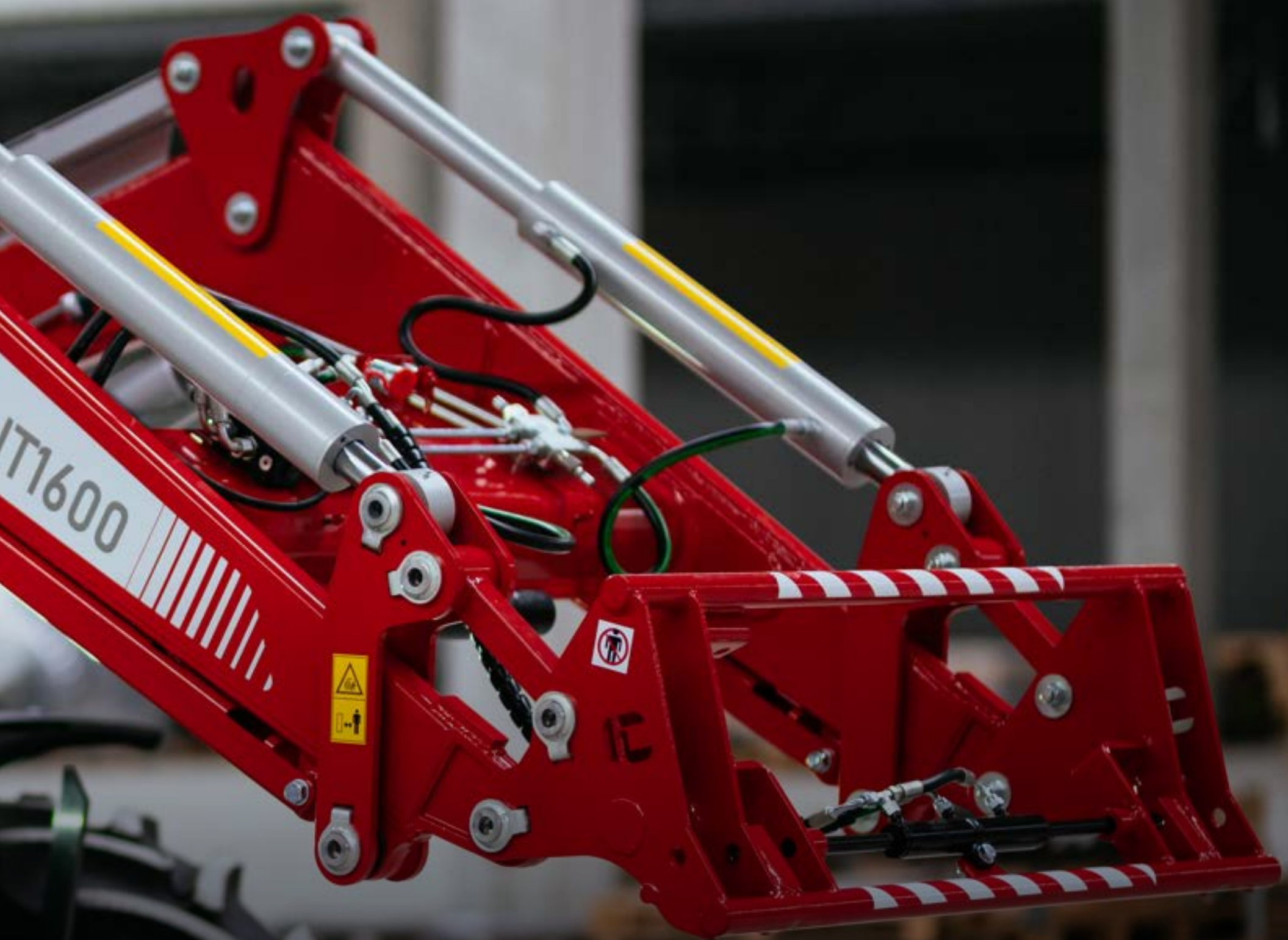

IT1600





# FRONT LOADER

## IT 1600



60-220 KM



1600 kg



3650-4150 mm

# FRONT LOADER IT1600

FRONT  
**LOADER**  
line

Model	IT 1600	IT 1600/S	IT 1600/L
Machine no	L2	L3	L4
Hydraulic cylinder (mm)	80/45/500	90/45/500	90/45/500
Load capacity (kg)	1600	1600	1600
Tractor power (HP)	60 – 120	70 – 150	120 – 220
Weight (kg)	590	630	670
Lifting height to the frame rotation axis (mm)	3650	3900	4150
Loading height (mm)	3400	3650	3900
Type of tools connection	EURO or SMS	EURO or SMS	EURO or SMS
Type of supports	Support foot	Support foot	Support foot
Steerage	Joystick	Joystick	Joystick
Type of mounting on the tractor	Bolts	Bolts	Bolts
Possibility to order a set	●	●	●
Possibility to order a loader boom without hydraulics	●	●	●
Possibility to order supporting structure and hydraulics	●	●	●
<b>Equipment</b>			
Frame EURO or SMS	✓	✓	✓
Self locking frame	✓	✓	✓
3-section hydraulic	✓	✓	✓
Joystick	✓	✓	✓
Color	✓	✓	✓
Piston shock absorber (€)	● ●	● ●	● ●
Quick connector (€)	○ ●	○ ●	○ ●
Electro-hydraulic divider (€)	●	●	●
Tilt indicator (€)	●	●	●
Hydraulic frame closing (€)	●	●	●
4-section (€)	●	●	●
Installation at the manufacturer's premises (€)	●	●	●
Installation at the dealer's or end customer's premises (€)	●	●	●
Service package	● ●	● ●	● ●



- ✓ Standard equipment
- Optional equipment
- Option not available
- Recommended
- Especially recommended



IT 1300

# Make full use of the power of your machine





# FRONT LOADER

## IT1300



60-120 KM



1300 kg



3650 mm

# FRONT LOADER IT1300

## FRONT LOADER line

<b>Model</b>	<b>IT1300</b>
Machine no	L1
Hydraulic cylinder (mm)	70/40/500
Load capacity (kg)	1300
Tractor power (HP)	60 – 120
Weight (kg)	590
Lifting height to the frame rotation axis (mm)	3650
Loading height (mm)	3400
Type of tools connection	EURO or SMS
Type of supports	Support foot
Steerage	Joystick
Type of mounting on the tractor	Bolts
Possibility to order a set	●
Possibility to order a loader boom without hydraulics	●
Possibility to order supporting structure and hydraulics	●
<b>Equipment</b>	
Frame EURO or SMS	✓
Self locking frame	✓
3-section hydraulic	✓
Joystick	✓
Color	✓
Piston shock absorber (€)	● ●
Quick connector (€)	○ ●
Electro-hydraulic divider (€)	●
Tilt indicator (€)	●
Hydraulic frame closing (€)	●
4-section (€)	●
Installation at the manufacturer's premises (€)	●
Installation at the dealer's or end customer's premises (€)	●
Service package	● ●

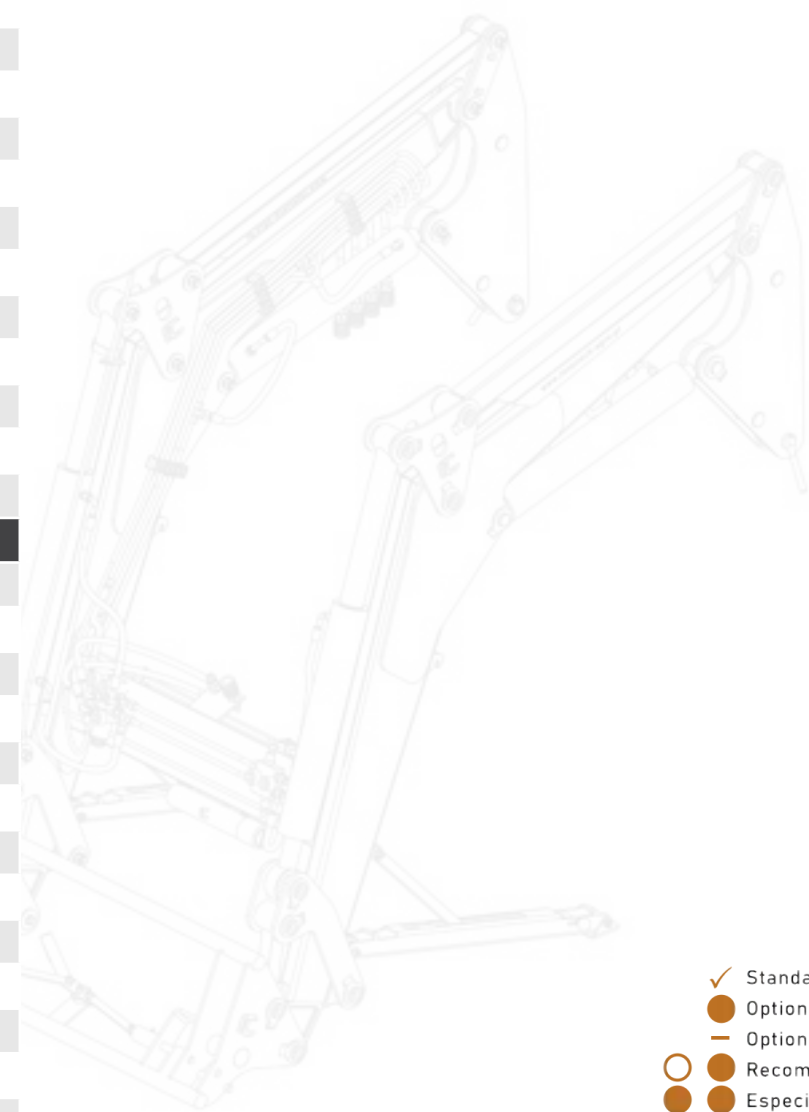

- ✓ Standard equipment
- Optional equipment
- Option not available
- Recommended
- Especially recommended



IT 1200

**The most popular choice for  
medium power tractors**





## FRONT LOADER

### IT 1200



50-80 KM



1200 kg



3200 mm

# FRONT LOADER IT1200

FRONT  
**LOADER**  
line

Model	IT1200
Machine no	L5
Hydraulic cylinder (mm)	70/40/500
Load capacity (kg)	1200
Tractor power (HP)	50 – 80
Weight (kg)	495
Lifting height to the frame rotation axis (mm)	3200
Loading height (mm)	2900
Type of tools connection	EURO or SMS
Type of supports	Support foot
Steerage	Joystick
Type of mounting on the tractor	Bolts
Possibility to order a set	●
Possibility to order a loader boom without hydraulics	●
Possibility to order supporting structure and hydraulics	●
Equipment	
Frame EURO or SMS	✓
Self locking frame	✓
3-section hydraulic	✓
Joystick	✓
Color	✓
Piston shock absorber (€)	● ●
Quick connector (€)	○ ●
Electro-hydraulic divider (€)	●
Tilt indicator (€)	●
Hydraulic frame closing (€)	●
4-section (€)	●
Installation at the manufacturer's premises (€)	●
Installation at the dealer's or end customer's premises (€)	●
Service package	● ●



- ✓ Standard equipment
- Optional equipment
- Option not available
- Recommended
- Especially recommended



IT 800

# Expand the capabilities of your tractor





# FRONT LOADER

## IT 800



30-60 KM



800 kg



2950 mm

# FRONT LOADER IT 800

## FRONT LOADER line

Model	IT 800
Machine no	L6
Hydraulic cylinder (mm)	50/32/500
Load capacity (kg)	800
Tractor power (HP)	30 – 60
Weight (kg)	305
Lifting height to the frame rotation axis (mm)	2950
Loading height (mm)	2800
Type of tools connection	EURO or SMS
Type of supports	Support foot
Steerage	Joystick
Type of mounting on the tractor	Bolts
Possibility to order a set	●
Possibility to order a loader boom without hydraulics	●
Possibility to order supporting structure and hydraulics	●
Equipment	
Frame EURO or SMS	✓
Self locking frame	—
3-section hydraulic	✓
Joystick	✓
Color	✓
Piston shock absorber (€)	● ●
Quick connector (€)	○ ●
Electro-hydraulic divider (€)	—
Tilt indicator (€)	●
Hydraulic frame closing (€)	●
4-section (€)	●
Installation at the manufacturer's premises (€)	●
Installation at the dealer's or end customer's premises (€)	●
Service package	● ●



- ✓ Standard equipment
- Optional equipment
- Option not available
- Recommended
- Especially recommended



IT 400

# Perfect solution for small tractors





## FRONT LOADER

### IT 400



20-40 KM



400 kg



2200 mm

# FRONT LOADER IT 400

## FRONT LOADER line

<b>Model</b>	IT 400
Machine no	L7
Hydraulic cylinder (mm)	40/22/370
Load capacity (kg)	400
Tractor power (HP)	20 – 40
Weight (kg)	250
Lifting height to the frame rotation axis (mm)	2200
Loading height (mm)	2050
Type of tools connection	EURO or SMS
Type of supports	Support foot
Steerage	Joystick
Type of mounting on the tractor	Bolts
Possibility to order a set	●
Possibility to order a loader boom without hydraulics	●
Possibility to order supporting structure and hydraulics	●
<b>Equipment</b>	
Frame EURO or SMS	✓
Self locking frame	—
3-section hydraulic	✓
Joystick	✓
Color	✓
Piston shock absorber (€)	● ●
Quick connector (€)	○ ●
Electro-hydraulic divider (€)	—
Tilt indicator (€)	●
Hydraulic frame closing (€)	—
4-section (€)	●
Installation at the manufacturer's premises (€)	●
Installation at the dealer's or end customer's premises (€)	●
Service package	● ●

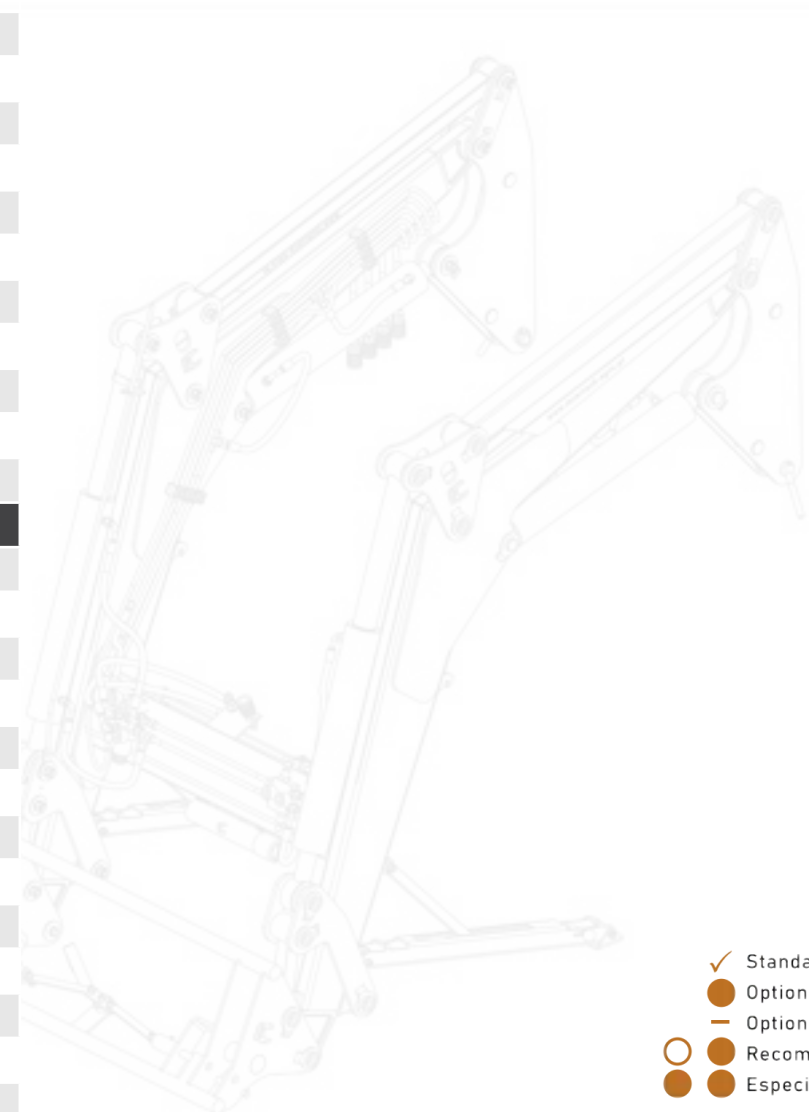

- ✓ Standard equipment
- Optional equipment
- Option not available
- Recommended
- Especially recommended

# THREE-POINT HITCH

The three-point hitch is a lever system used for hanging and attaching agricultural tools.

Control of the hitch can be either mechanical or automatic, and its range of manipulation includes lifting, lowering, and lateral movements. It allows for the attachment of a significantly larger number of machines and devices.

Its presence significantly increases the functionality of the tractor and enables the performance of several tasks with one machine, which in turn translates into savings of both time and money.

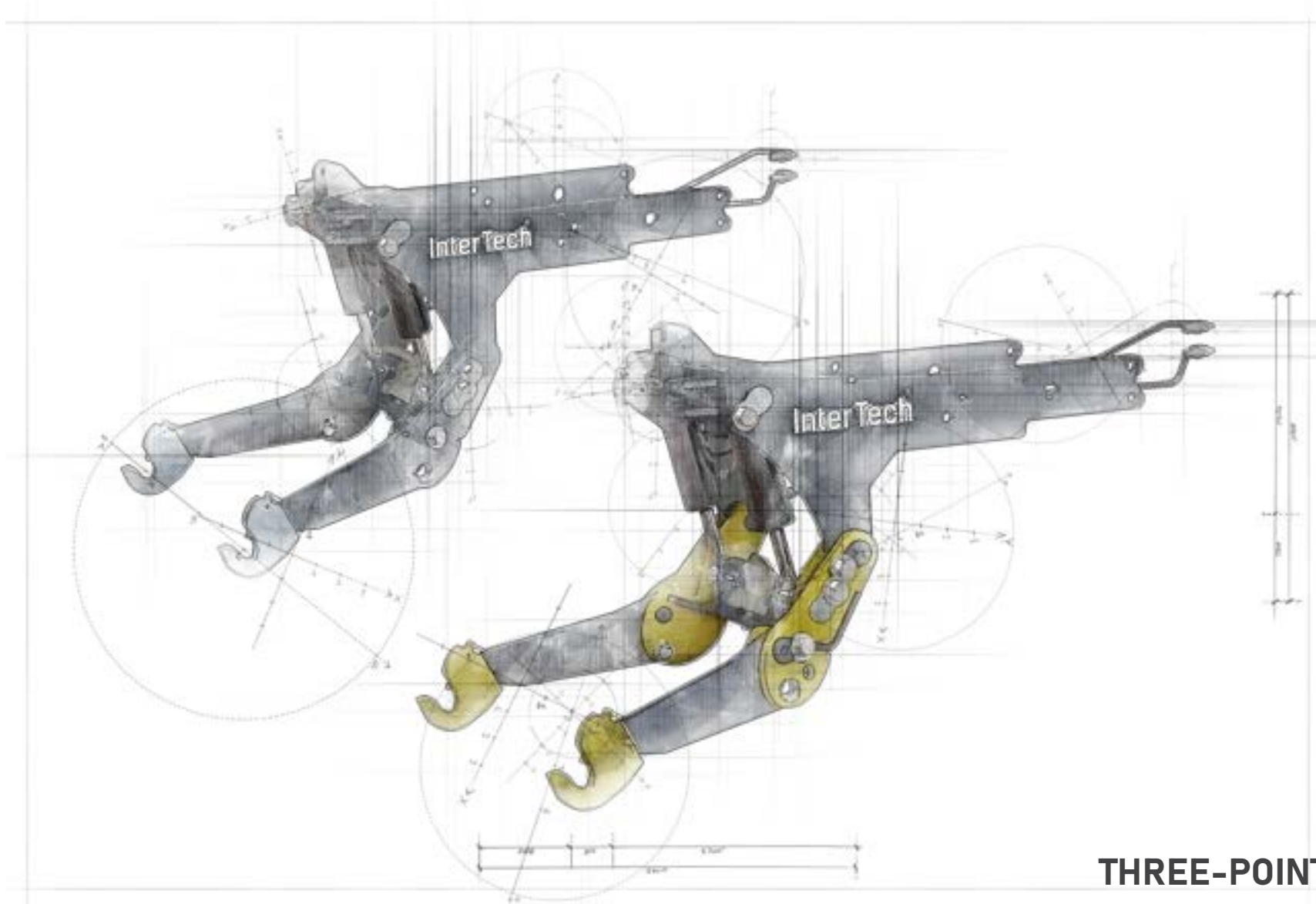

THREE-POINT HITCH

**Versatile fit**



## Three-Point Hitch



400 kg

## Three-Point Hitch

Model	ITFL2500	ITFL1200	ITFL400
Machine no	LT1	LT2	LT3
Load capacity (kg)	2500	1200	400
Weight (kg)	350	110	50
Shoulder stroke (mm)	765	765	370
Number of cylinders (pcs.)	2	2	2
Front linkage category	TUZ, cat. II, III	TUZ, cat. I, II	TUZ, cat. I
Cach hook	CBM cat. II, III	CBM cat. I, II	CBM cat. I, II
Steerage	Tractor hydraulic	Tractor hydraulic	Tractor hydraulic
Equipment			
Double acting hydraulic cylinders	✓	✓	✓
Extendable arms	✓	✓	✓
Hydraulic hoses	✓	✓	✓
External hydraulic outputs (€)	●	●	✓
Electrical output for lights	●	●	—
3 pin electrical output	●	●	—
Control with the help of a joystick (additional splitter required) (€)	●	●	○ ●
Service package	● ●	● ●	● ●

- ✓ Standard equipment
- Optional equipment
- Option not available
- Recommended
- Especially recommended





## GUARANTEE

We guarantee a professional service and professional advice. Every customer is important to us.



## ENVIRONMENT

We use renewable energy sources.



## TRANSPORT



We offer logistical support. Safe delivery of purchased machines.

[www.itlogistic.pl](http://www.itlogistic.pl)



## SAFETY

We build with your safety in mind.

**work safely**



## SERVICE

Helpline service 24/7 Diagnosis, assistance and expert advice in case of any emergencies and questions regarding the use of the machines. We are there when you need us, whatever happens you have our support.

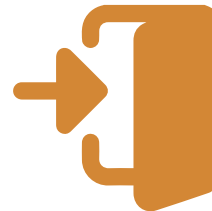

## AVAILABILITY



Online at all times.

enova365



**work safely**



-  532 777 770
-  Aleja Wojska Polskiego 100,  
18-300 Zambrów
-  [facebook.com/InterTechZambrow](https://facebook.com/InterTechZambrow)
-  [intertech\\_agro](https://instagram.com/intertech_agro)
-  [InterTechAgro](https://www.youtube.com/InterTechAgro)
-  [sekretariat@intertech-agro.pl](mailto:sekretariat@intertech-agro.pl)
-  [www.intertech-agro.pl](http://www.intertech-agro.pl)



**work safely**

**GREEN**

line





**work safely**





Catalogue valid as of 16/10/2023. Please quote name and catalogue number when ordering. The images in the catalogue may differ from the product on sale. The photos may include additional options which are not included in the standard equipment.

Inter Tech reserves the right to change technical parameters and other physical characteristics. Inter Tech reserves the right to make changes to the products without informing the customer. The weights given are approximate and may differ from the actual weight depending on equipment and configuration. The catalogue is for information purposes only and does not constitute a commercial offer within the meaning of Article 543 of the Civil Code. The General Terms and Conditions of Sale (GTS) are available on the Inter Tech website [www.intertech-agro.pl](http://www.intertech-agro.pl).

# Mission



Fusion of passion, knowledge, commitment in an ever-changing world.

# Vision



We are the company that best in agribusiness YESes care of relationships according to individual customer needs.



# Courage



- Boldness and openness
- Determination
- Commitment and passion for common goals

# Partnership



- Human First
- Building lasting relationships
- Commitment

# Development



- Emphasis on innovation
- Development of skills and knowledge
- Searching for better and better solutions, meeting customers by constantly improving quality.

We are intensively developing the sales segment and new products and services. We are adapting our business profile to be fully customer-focused. The values reflect the way Inter Tech wants to achieve its goals. The essence of the Human First partnership is customer focus, building lasting relationships and commitment. We actively increase the potential of new products through the fusion of modern contact channels and compatible services. Development means an emphasis on innovation, development of skills and knowledge and the search for ever better solutions, meeting customers by constantly improving quality. Courage means boldness and openness, determination as well as commitment and passion in achieving common goals. The combination of these values leads to a better understanding of customer expectations, allows us to respond to market challenges and strengthens the Inter Tech Family's corporate culture.

# Inter Tech Family

A fusion of passion, knowledge, commitment in an ever-changing world.

We have nothing to hide. Inter Tech is more than a company.

It is a community where everyone is treated like a family member.

There are few family businesses that build a lasting foundation in international relationships having a significant impact on agricultural development.

Inter Tech Family is the ideal place for ambitious, enthusiastic people looking for inspiration in their development, for whom gaining professional experience is a great motivation for work and a source of satisfaction.

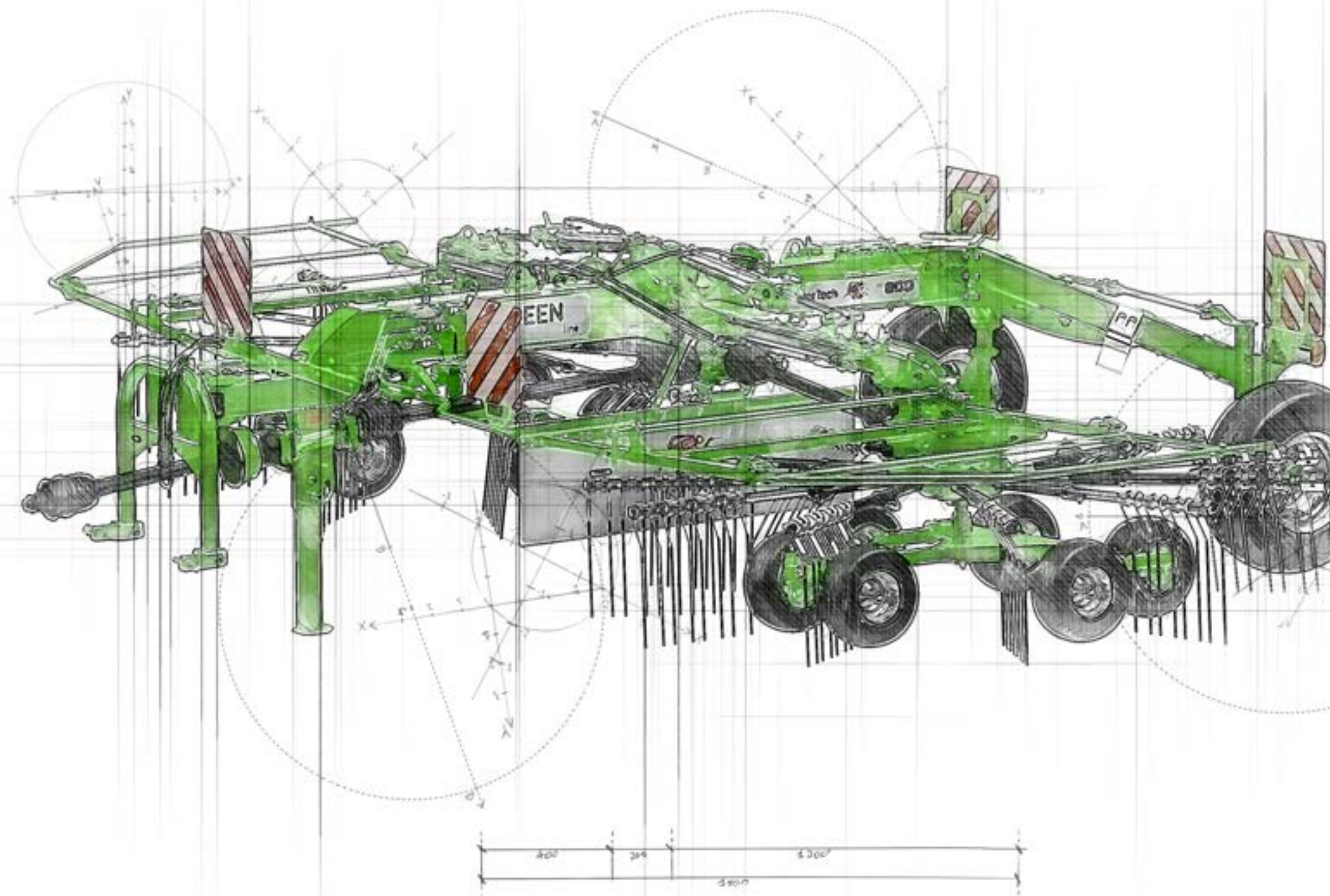



# Green Line

Bio-balance - focus on results, not just on meadows.

We are aware that the nutrition of the herd matters.

We have set a goal to find a balance between the high nutritional value of fodder and the optimization of production costs. Thanks to the wide range of reliable machines from our portfolio, this plan is easy to achieve.

Furthermore, the application of innovative solutions guarantees the protection of grasslands and prevents their overexploitation.



ZKT-350 1-ROTOR ROTARY RAKE

**Ideal for small  
and uneven surfaces.**

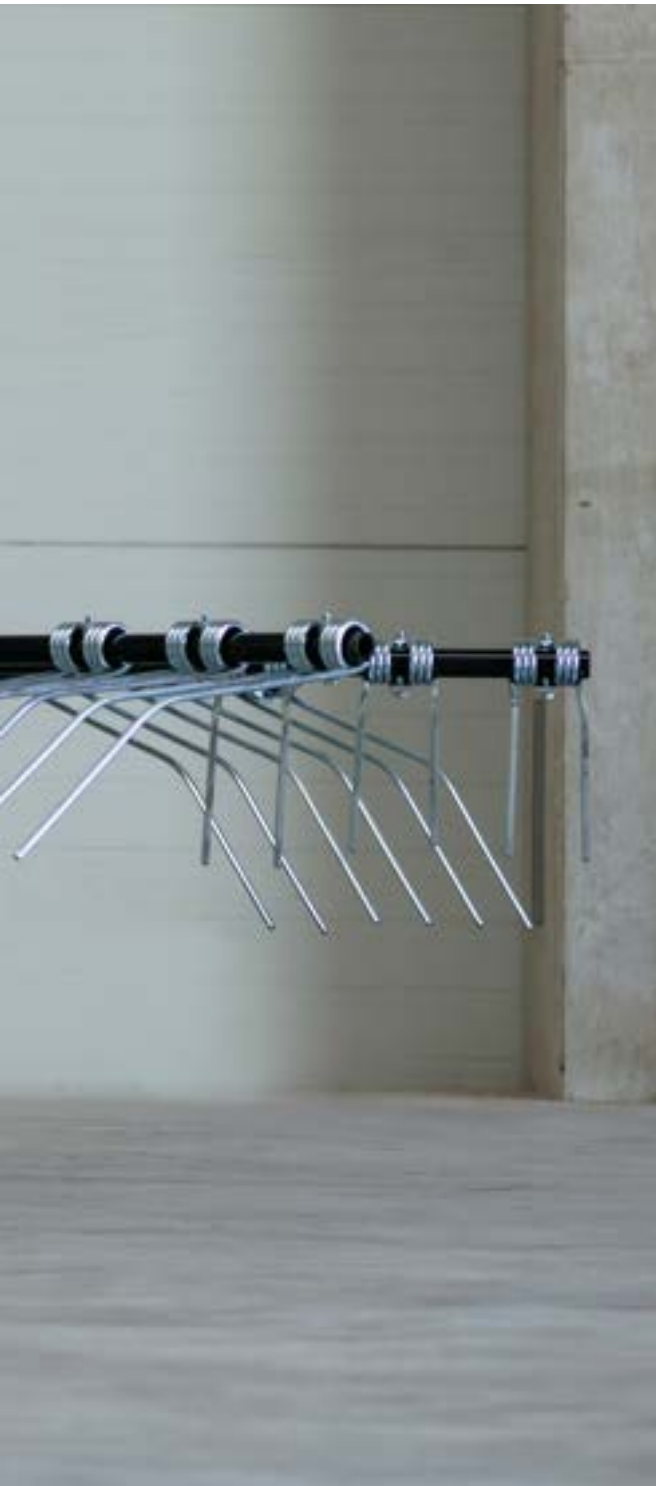

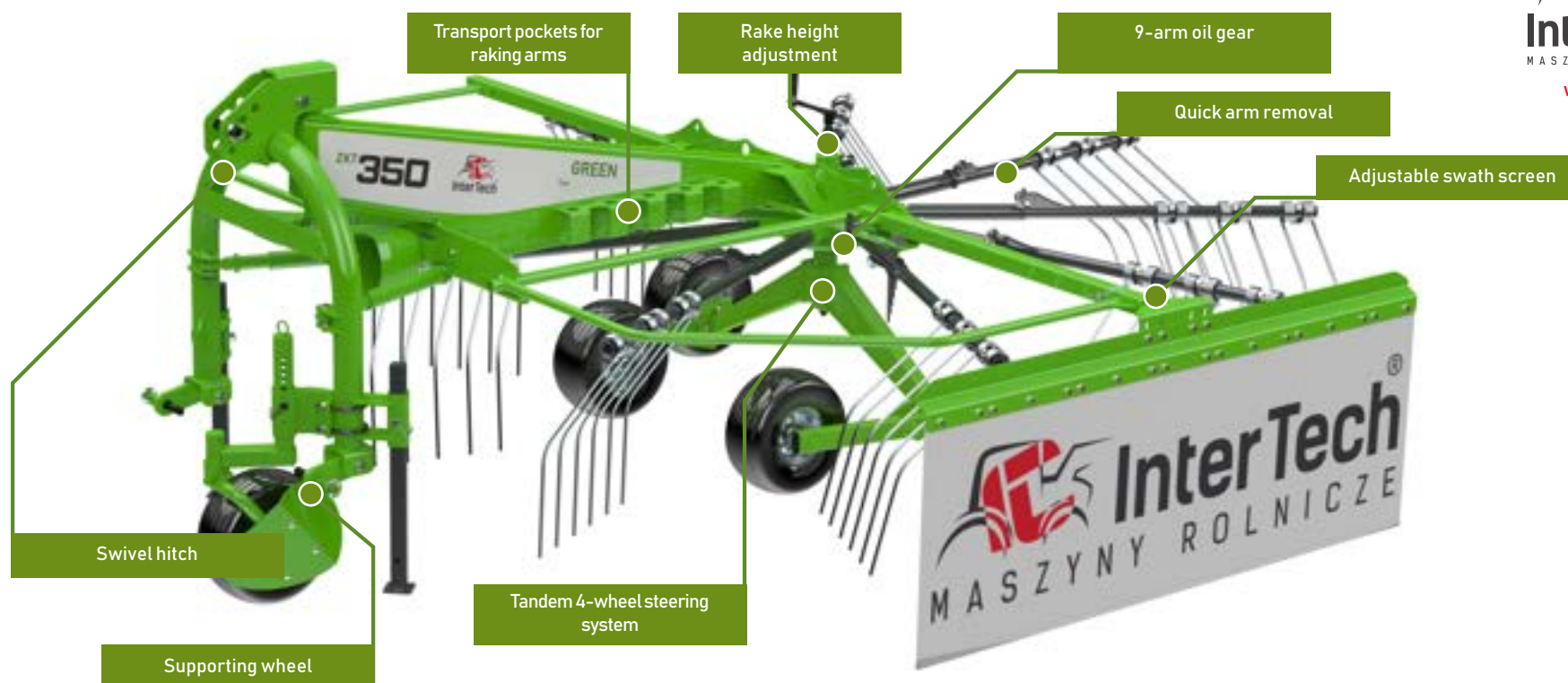

## ZKT-350 ROTARY RAKE 1-ROTOR

The raking width is 3.5m, making it suitable for use in smaller farms. The special design of the rakes enhances comfort and stability during operation when turning and on sloping ground. For ease of transport, the arms are detachable and set on the frame of the rake. The swath screen is adjustable without the use of tools, which is extremely practical when working in the field. An additional benefit are the supporting wheels mounted close to the rotor, which allows the raking fingers to more accurately follow the contours of the ground, resulting in less contaminated fodder.



MIN. 25 KM



3,5 m



9 szt.

# GREEN

line

## ZKT-350 ROTARY RAKE 1-ROTOR

Model	ZKT-350
Machine no	GZJ01
Rake width (m)	3,5
Width of the rake roller (m)	0,80 – 1,50
Effective output (ha/h)	3,0 – 4,0
Number of working arms (pcs.)	9
Number of tines (pcs.)	27
Turnover WOM (rpm)	350 – 450
Minimum tractor power (HP)	25
Type of suspension	Active, TUZ Kat. I, II
Suspension category	Tandem/4 wheels
Weight (kg)	480
Equipment	
Clutch PTO	✓
Absorbing twist hitch	✓
9-arm oil gear	✓
Tandem 4-wheel drive system	✓
Adjustment of the width of the raked roller	✓
Rake height adjustment	✓
Adjustable swath screen	✓
Removable arms for transport	✓
Supporting wheel (€)	● ●
Service package	● ●

- ✓ Standard equipment
- Optional equipment
- Option not available
- Recommended
- Especially recommended



ZKT-420 ROTARY RAKE 1-ROTOR

**The quality of forage has  
a direct impact on milk production.**



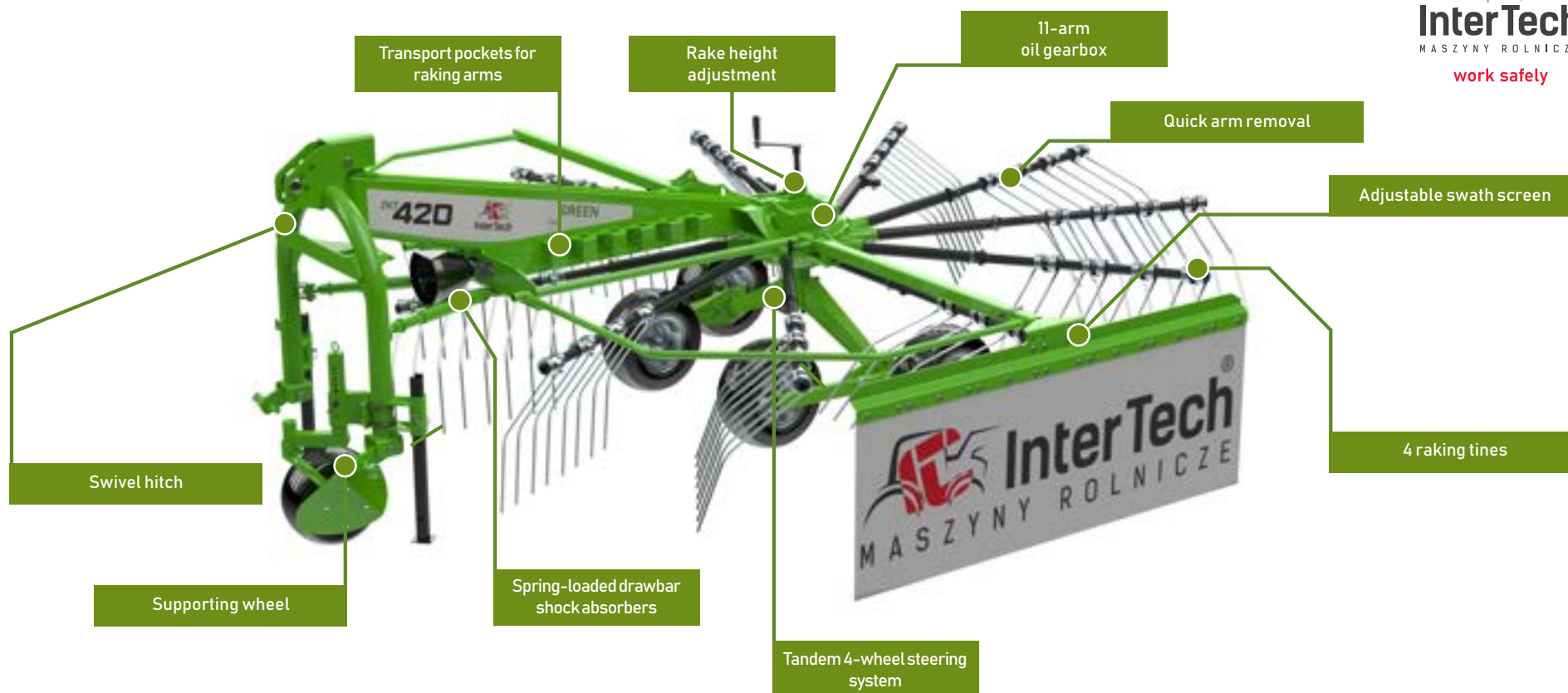

## ZKT-420 ROTARY RAKE 1-ROTOR

The raking width is 4.2 m, therefore they are dedicated for use in smaller farms. The special design of the rakes increases the comfort and stability of work when driving on headlands and sloped terrain. To facilitate transport, the arms are detachable and placed on the frame of the rake. The swath screen is adjustable without the use of tools, which is highly practical when working in the field. An additional benefit are the supporting wheels mounted close to the rotor, allowing the raking fingers to more accurately follow the terrain's contour, resulting in less contaminated fodder.



MIN. 40 KM



4,2 m



11 szt.

# GREEN

line

## ZKT-420 ROTARY RAKE 1-ROTOR

Model	ZKT-420
Machine no	GZJ02
Rake width (m)	4,2
Width of the rake roller (m)	0,80 – 1,50
Effective output (ha/h)	4,0 – 5,0
Number of working arms (pcs.)	11
Number of tines (pcs.)	44
Turnover WOM (rpm)	350 – 450
Minimum tractor power (HP)	40
Type of suspension	Active, TUZ Kat. I, II
Suspension category	Tandem/4 wheels
Weight (kg)	600
<b>Equipment</b>	
Clutch PTO	✓
Absorbing twist hitch	✓
11-arm oil gear	✓
Tandem 4-wheel drive system	✓
Adjustment of the width of the raked roller	✓
Rake height adjustment	✓
Adjustable swath screen	✓
Removable arms for transport	✓
Supporting wheel (€)	● ●
Service package	● ●

- ✓ Standard equipment
- Optional equipment
- Option not available
- Recommended
- Especially recommended



ZKD-800 ROTARY RAKE 2-ROTOR

**The leader of meadow,  
naturally.**





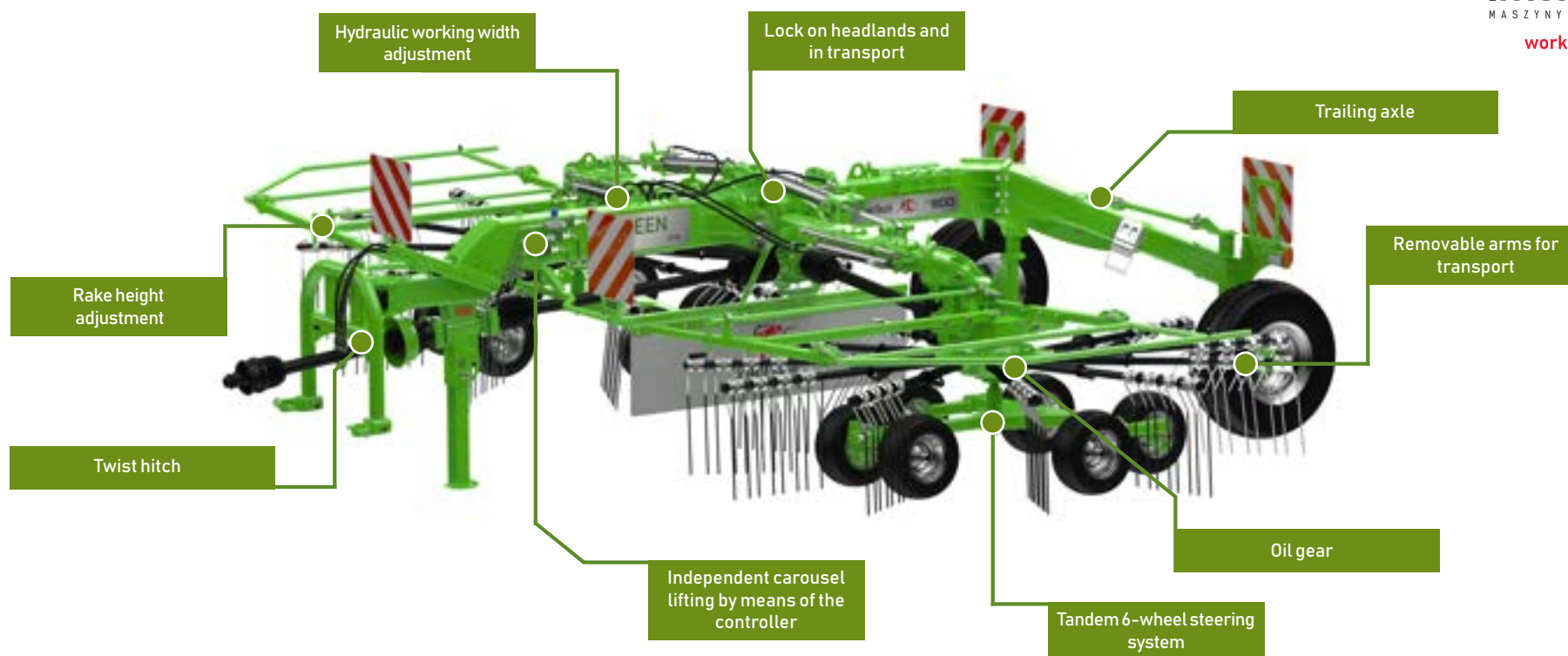

## ZKD-800 ROTARY RAKE 2-ROTOR

A rake with two rotors forming a swath is a reliable partner even in difficult conditions. Regardless of the type of cut plant mass or terrain contour, it evenly lays down the loose swath, influencing its high quality and the efficiency of subsequent machines in the production line. Its characteristic feature is the precise copying of ground irregularities, thanks to the adjustment of the supporting wheels of the carousel chassis. The high quality of the swath depends, among other things, on the number of arms on the carousel and the adjustment of the raking height. The ZKD-800 rake allows for lowering the raking fingers to a level that provides a clean harvest image – without losses.



MIN. 60 KM



6,8–7,8 m



2250 kg

# ZKD-800 ROTARY RAKE 2-ROTOR

**GREEN**

line

Model	ZKD-800
Machine no	GZD01
Rake width (m)	6,8 – 7,8
Width of the rake roller (m)	1,5 – 2,0
Effective output (ha/h)	8,0 – 9,5
Number of working arms (pcs.)	22
Number of tines (pcs.)	88
Turnover WOM (rpm)	540
Minimum tractor power (HP)	60
Type of suspension	Semi-mounted, TUZ Kat. I, II
Suspension category	Tandem/6 wheels for on rotor
Weight (kg)	2250
Equipment	
Clutch PTO	✓
Twist hitch	✓
Oil gear	✓
Tandem 6-wheel steering system	✓
Hydraulic working width adjustment	✓
Lock on headlands and in transport	✓
Warning signs	✓
Lightning	✓
Protection for losing tines	✓
Independent carousel lifting by means of the controller	✓
Rake height adjustment	✓
Adjustable swath screen	✓
Removable arms for transport	✓
Wide wheels 340/55 R16	✓
Springs unloading working systems (€)	● ●
Service package	● ●



- ✓ Standard equipment
- Optional equipment
- Option not available
- Recommended
- Especially recommended



TEDDER

Guarantee of dry matter



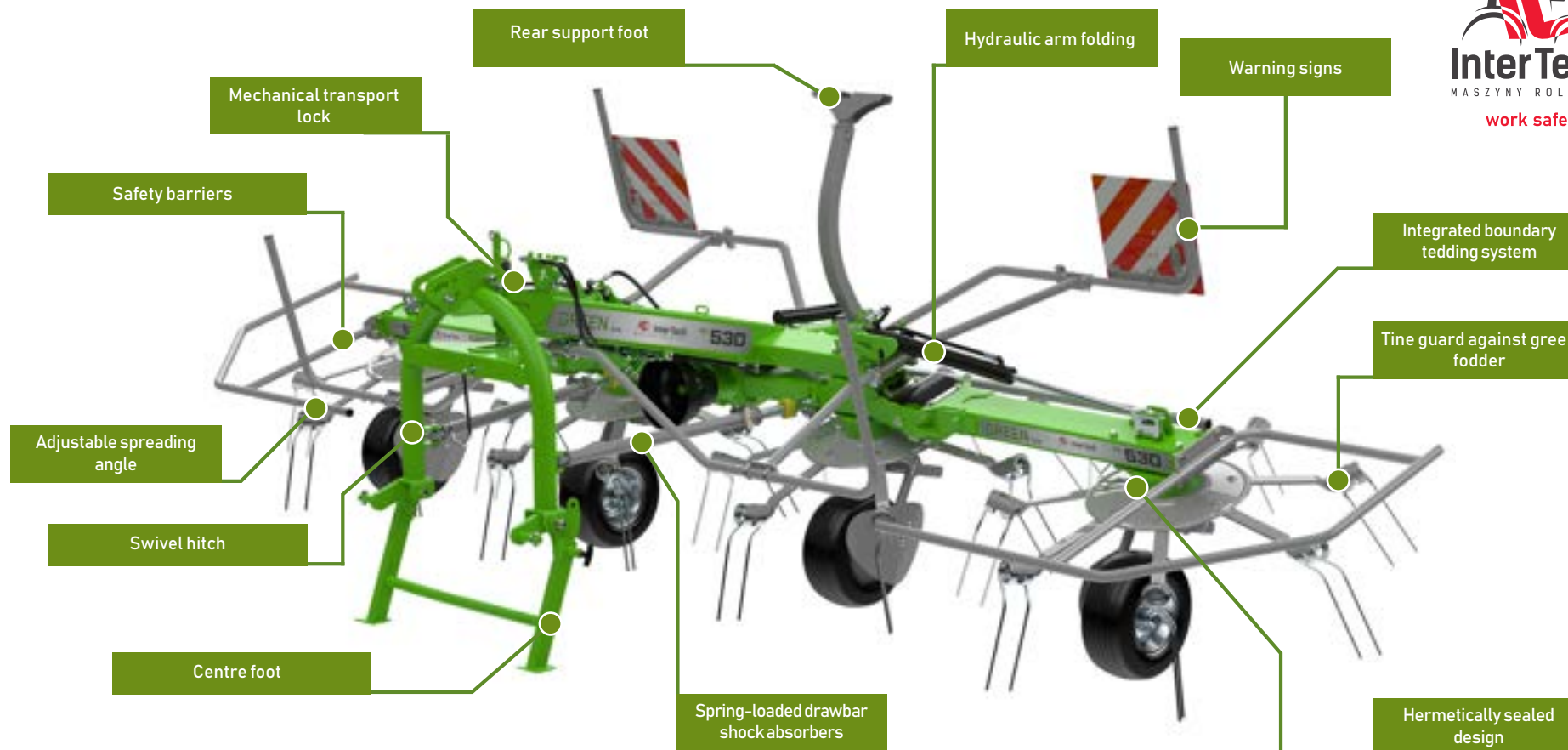

## TEDDER

It has been designed to ensure optimal forage preparation and reliable operation. The highly efficient rotary device guarantees high work comfort, reduces the moisture of the cut green fodder and dried hay before harvesting, accelerating the drying process. At the same time, it prevents the loss of nutrients such as protein and carotene.



MIN. 30 KM



4,6-7,7 m



4-6 szt.

# TEDDER

# GREEN

line

Model	ZKP-460	ZKP-530	ZKP-770
Machine no	GP01	GP02	GP03
Rake width (m)	4,6	5,3	7,7
Number of rotor (pcs.)	4	4	6
Number of arms on one rotor (pcs.)	6	7	7
Turnover WOM (rpm)	350 – 450	350 – 450	350 – 450
Minimum tractor power (HP)	30	40	50
Effective output (ha/h)	4,5 – 5,7	5,8 – 6,5	8,5 – 9,5
Type of suspension	Active, TUZ Kat. I, II	Active, TUZ Kat. I, II	Active, TUZ Kat. I, II
Weight (kg)	610	695	925
Equipment			
Clutch PTO	✓	✓	✓
Absorbing twist hitch	✓	✓	✓
Carousel gear (grease lubricated)	✓	✓	✓
Adjustable angle of forage spreading	✓	✓	✓
Wheels with adjustable working angle	✓	✓	✓
Integrated boundary tedding system	✓	✓	✓
Warning signs	✓	✓	✓
Lightning	✓	✓	✓
Hydraulic arm folding	✓	✓	✓
Protection for losing tines	✓	✓	✓
Central gear in oil bath	✓	✓	✓
Supporting wheel (€)	● ●	● ●	● ●
Service package	● ●	● ●	● ●

- ✓ Standard equipment
- Optional equipment
- Option not available
- Recommended
- Especially recommended





BALE WRAPPER SELF LOADING WITH SIDE LOADING

**Baling. A cost-effective practice  
in your farm.**



## BALE WRAPPER

### SELF LOADING WITH SIDE LOADING

The reliable and durable wrapper is used to pick up a compressed bale from the ground using a loading arm onto the working table. The unique loading system eliminates the need to stop during loading, which increases work ergonomics. Proper wrapping of the bales by optimally overlapping the individual layers of film ensures that the fermentation process begins immediately after wrapping is completed. This guarantees the maintenance of high-quality fodder throughout the storage period. The hydraulic foil cutting system significantly affects work efficiency and time savings.



MIN. 50 KM



1000-1200 mm



1,3-2 min

# BALE WRAPPER SELF LOADING WITH SIDE LOADING

## GREEN

line

Machine no	G001
Bale diameter (mm)	1000 – 1200
Foil width (mm)	500/750
Number of table turnover (per min.)	24 (Foil 500)/16 (Foil 750)
Czas owinięcia beli (min)	2 (Foil 500)/1,3 (Foil 750)
Minimum tractor power (HP)	50
Bale loading	Lateral, through the loading arm
Bale unloading	Self-acting, through the table swivel frame
Steerage	Tractor hydraulic
Folding the wheel for transport	YES
Weight (kg)	1270
<b>Equipment</b>	
Bale setter	✓
Hydraulic, automatic foil cutter	✓
Hydraulic, automatic foil creaser	✓
Electronic wrapping counter	✓
Automatic bale wrapping function	✓
Rotary-belt table	✓
„Soft” start and stop	✓
Foil dispenser 500/750	✓
Lightning	✓
Support foot	✓
Hydraulic drive	✓
Approval of UE (€)	●
Wide wheels 340/55 R16	● ●
Service package	● ●

- ✓ Standard equipment
- Optional equipment
- Option not available
- Recommended
- Especially recommended



CORN SCRAPER

**Shape the silage stacks as needed**

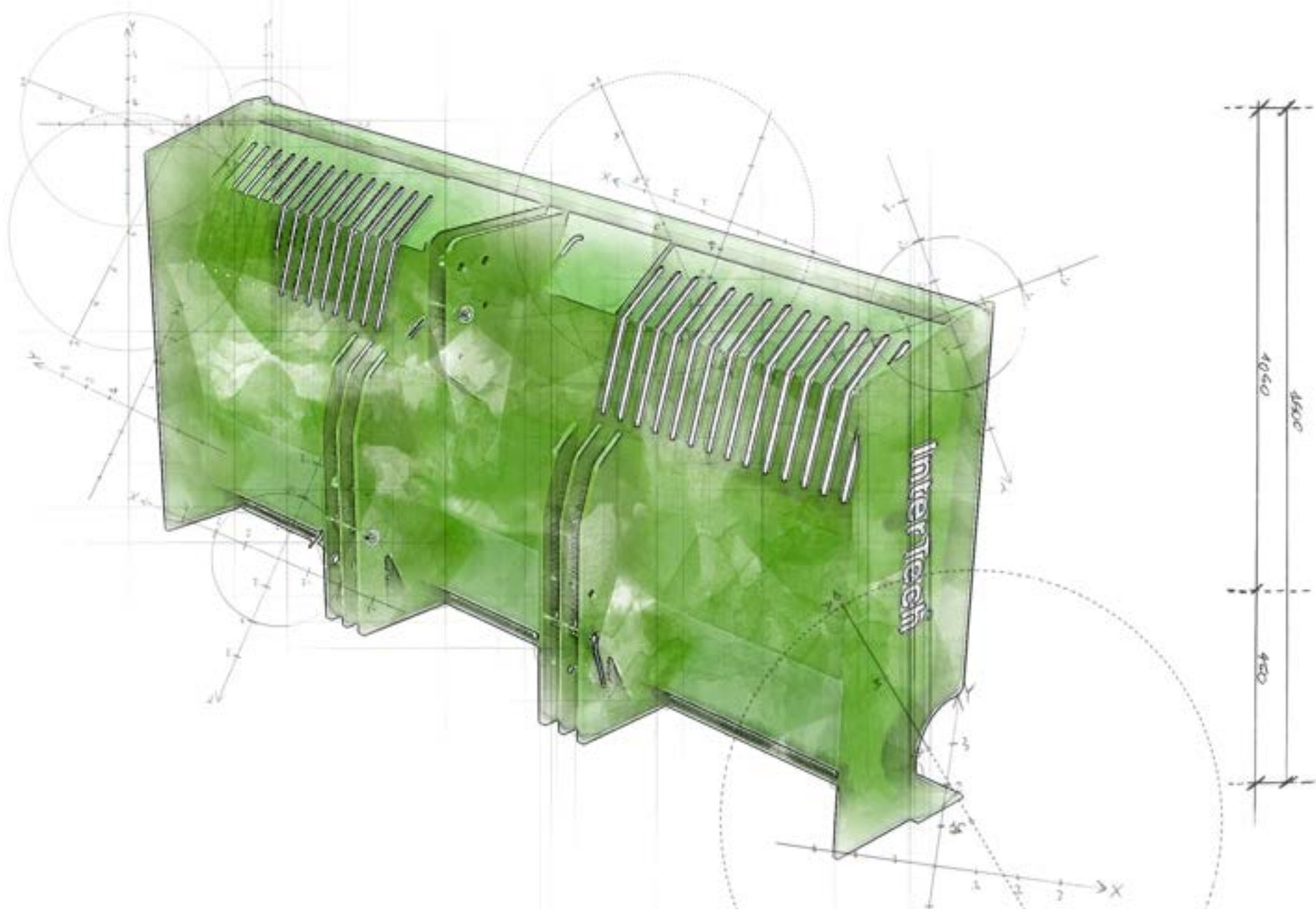

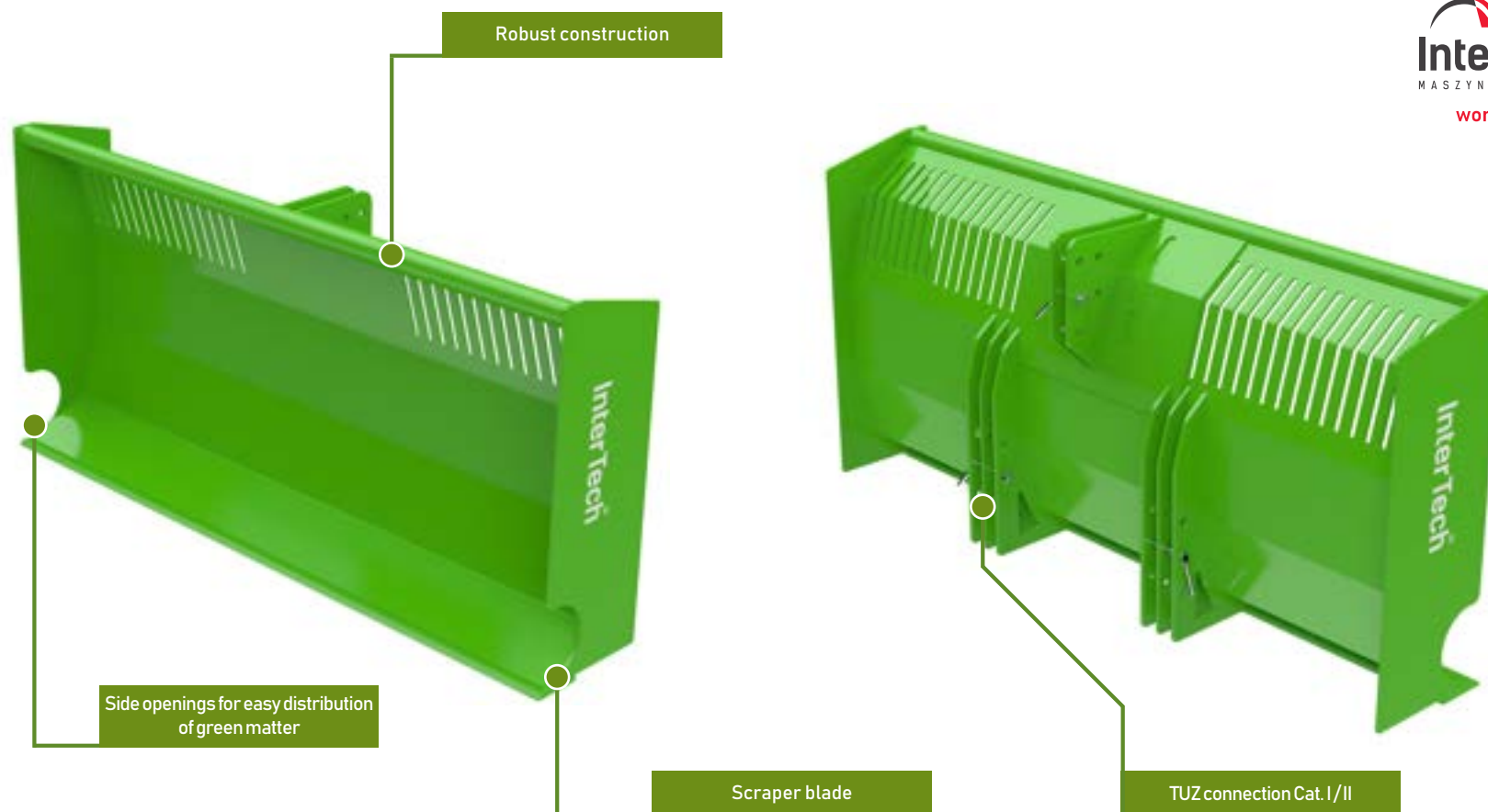

## CORN SCRAPER

It is designed for shaping the surface of corn silage stacks, as well as pushing it to higher parts. The use of a strong mouldboard blade optimizes the time associated with the preparation of corn silage.



2,9–3,7 m



1,4 m

# GREEN

line

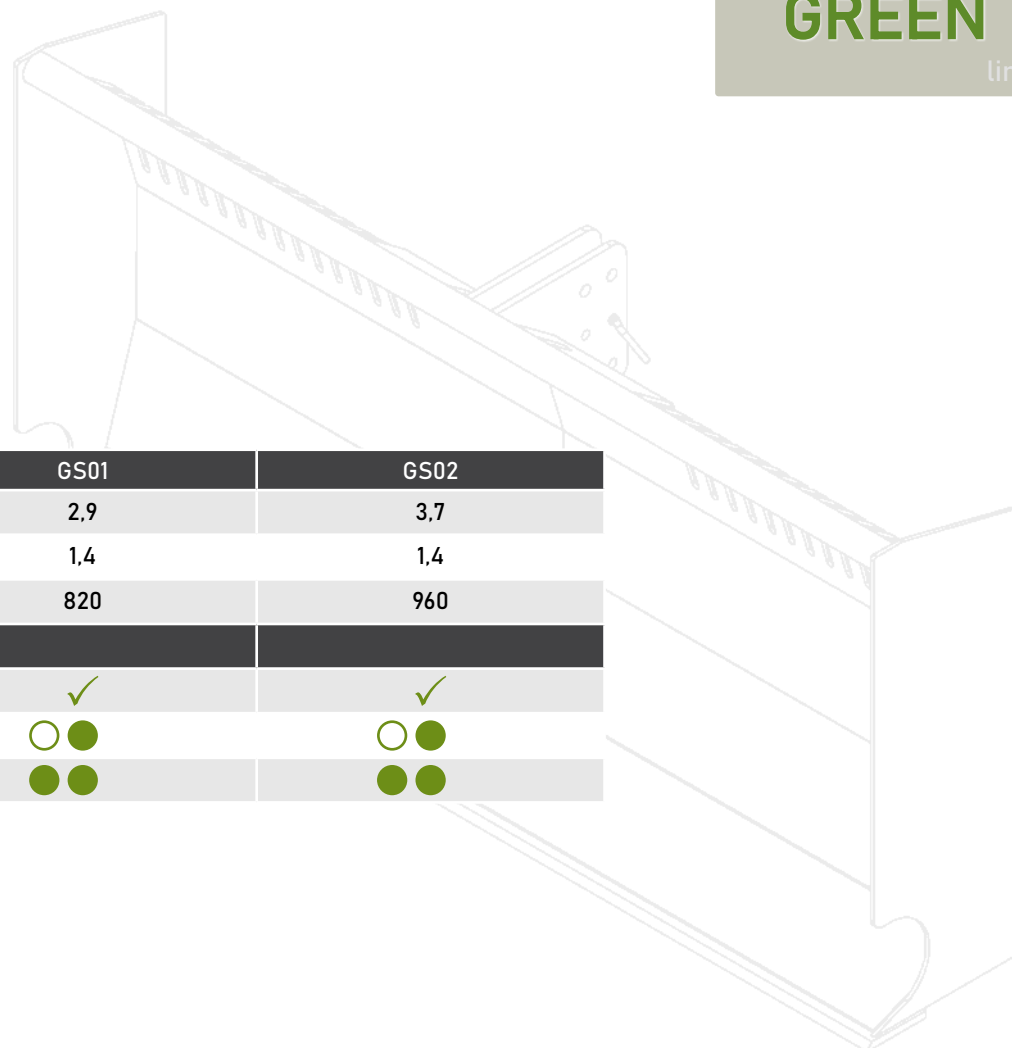

## CORN SCRAPER

Machine no	GS01	GS02
Width (m)	2,9	3,7
Mouldboard height (m)	1,4	1,4
Weight (kg)	820	960
Equipment		
TUZ connection Cat. I/II	✓	✓
Lightning	○ ●	○ ●
Service package	● ●	● ●

- ✓ Standard equipment
- Optional equipment
- Option not available
- Recommended
- Especially recommended

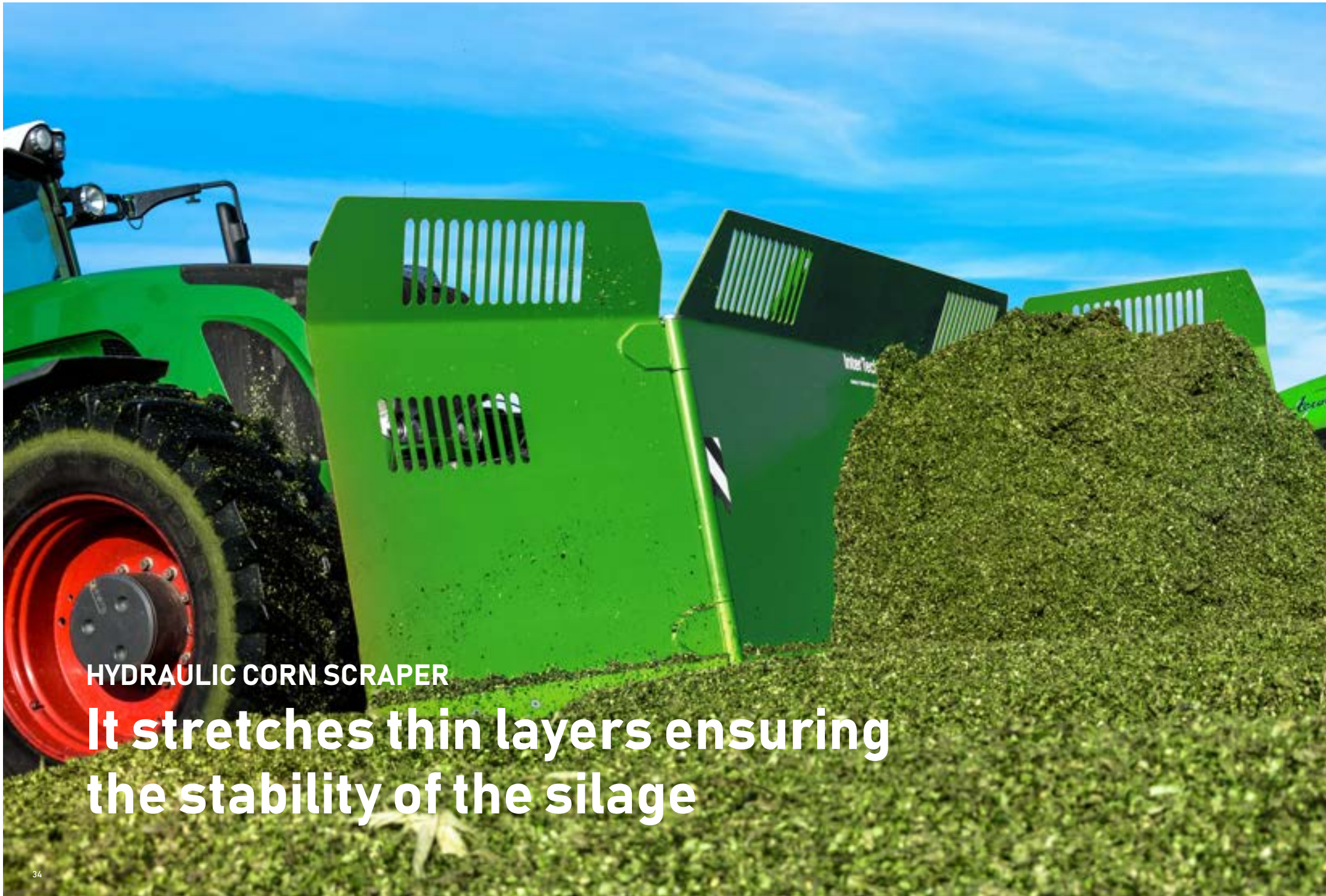

**HYDRAULIC CORN SCRAPER**

**It stretches thin layers ensuring  
the stability of the silage**



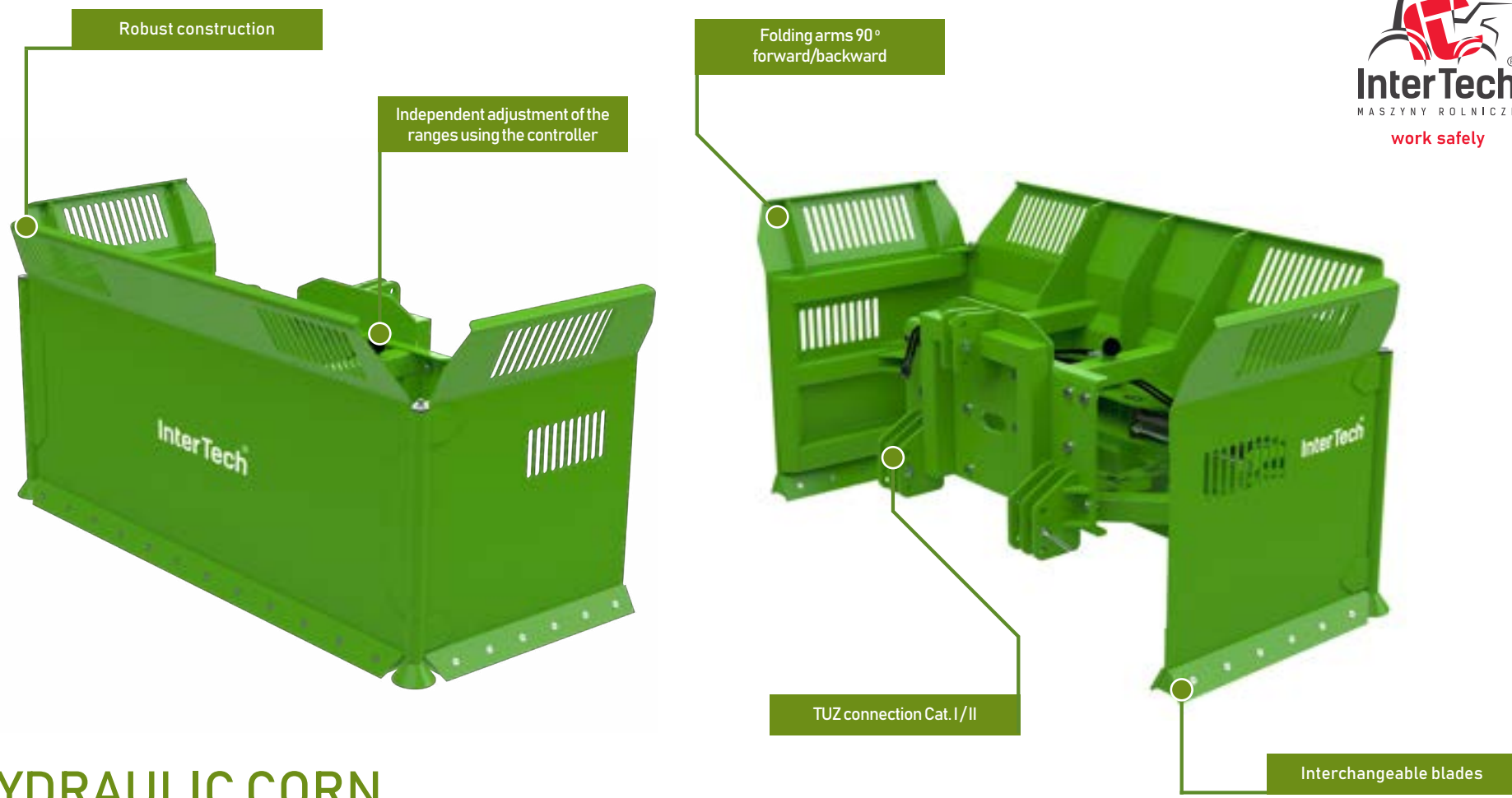

## HYDRAULIC CORN SCRAPER

It is intended for shaping the surface of corn silage stacks, as well as pushing the silage to higher parts. The extended hitch improves visibility and increases the range of work. It is also used in biogas plants for preparing corn silage, where proper preservation depends on the precise and swift formation of the stack.

  
5 m

  
0,8-1,4 m

# GREEN

line

## HYDRAULIC CORN SCRAPER

Machine no	GS03	GS04	GS05
Width (m)	5,0	5,0	5,0
Minimum working width (m)	2,7	2,7	2,7
Maximum working width (m)	5,0	5,0	5,0
Mouldboard height (m)	0,8	1,2	1,4
Number of cylinders (pcs.)	2	2	2
Weight (kg)	1080	1560	1670
<b>Equipment</b>			
TUZ connection Cat. I /II	✓	✓	✓
Independent adjustment of the arms using a controller	✓	✓	✓
Lightning	○ ●	○ ●	○ ●
Service package	● ●	● ●	● ●

- ✓ Standard equipment
- Optional equipment
- Option not available
- Recommended
- Especially recommended



HYDRAULIC CORN SCRAPER TYPE V

**The highest level of control**



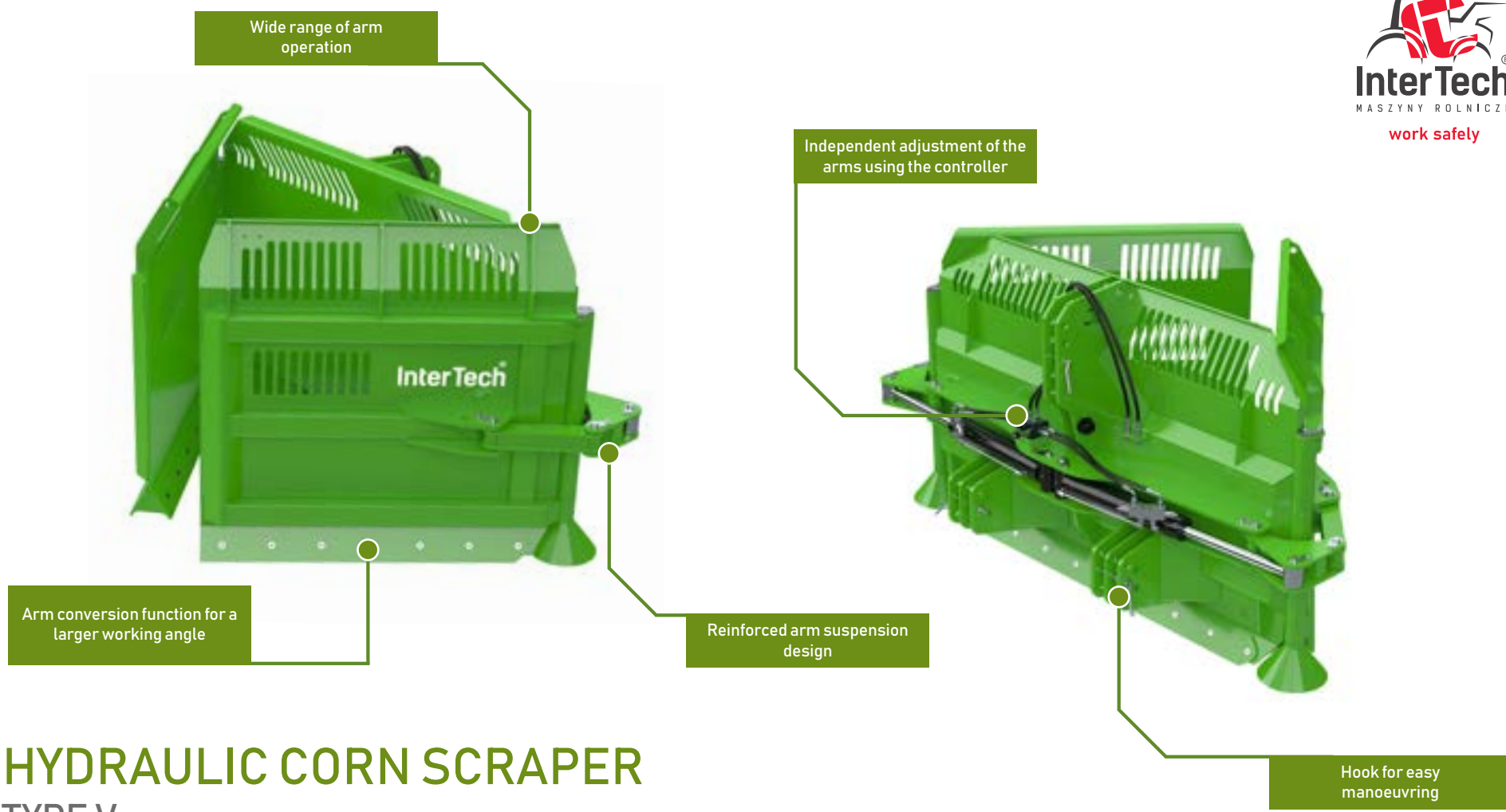

# HYDRAULIC CORN SCRAPER TYPE V

It is designed for shaping the surface of corn silage stacks, as well as pushing it to higher sections. The tiltable side wings work excellently in the most demanding and difficult conditions. Wear-resistant, replaceable mouldboards are mounted on the bottom, and the shortened hitch reduces the tractor's load during operation.



5,3 m



0,8-1,4 m

# GREEN

line

## HYDRAULIC CORN SCRAPER TYPE V

Machine no	GS06	GS07	GS08
Width (m)	5,3	5,3	5,3
Minimum working width (m)	2,3	2,3	2,3
Maximum working width (m)	5,3	5,3	5,3
Mouldboard height (m)	0,8	1,2	1,4
Number of cylinders (pcs.)	2	2	2
Weight (kg)	1050	1450	1600
Equipment			
TUZ connection Cat. I / II	✓	✓	✓
Independent adjustment of the arms using a controller	✓	✓	✓
Lightning	○ ●	○ ●	○ ●
Service package	● ●	● ●	● ●

- ✓ Standard equipment
- Optional equipment
- Option not available
- Recommended
- Especially recommended





SILAGE COMPACTOR

**Precise compaction enhances  
the ensiling process.**



## SILAGE COMPACTOR

An excellent solution for farms preserving fodder in stacks and silos. Its durable and compact construction affects the longevity of use. The hydraulically controlled, tire compactor for silage stacks provides intensive, deep, and even compaction of the green mass. It ensures proper in-depth compaction of the material in the silo and stack. There is an option to fill the roller with water, which increases its pressure force. The use of a compaction roller positively affects the quality of the silage and reduces losses.



150 KM



3–4,7 m



2020–3420 kg

# GREEN

line

## SILAGE COMPACTOR

Machine no	GWD01 (Without shift)	GWD02 (With shift)	GWD02 (Without shift with the pile compactor)	GWD04 (With shift with the pile compactor)
Width (m)	3,2	3,3	3,2	3,3
Working width (m)	3	3	3	3
Working width with silage compactor (m)	-	-	4,5	4,5
Minimum tractor power (HP)	120	120	150	150
Hitch category	TUZ, kat. II, III	TUZ, kat. II, III	TUZ, kat. II, III	TUZ, kat. II, III
Shaft diameter (mm)	1000	1000	1000	1000
Number of cylinders (pcs.)	-	2	1	3
Number of required hydraulic connections pairs	-	1	1	2
Own weight (kg)	2050	2250	2530	2730
Weight after filling (kg)	3200	3400	3680	3880
Equipment				
Hydraulic side shift	-	●	-	●
Pile compactor	-	-	✓	✓
Lightning	○ ●	○ ●	○ ●	○ ●
Service package	● ●	● ●	● ●	● ●

- ✓ Standard equipment
- Optional equipment
- Option not available
- Recommended
- Especially recommended



**GREEN**

line



## GUARANTEE

We guarantee a professional service and professional advice. Every customer is important to us.



## ENVIRONMENT

We use renewable energy sources.



## TRANSPORT



We offer logistical support. Safe delivery of purchased machines.

[www.itlogistic.pl](http://www.itlogistic.pl)



## SAFETY

We build with your safety in mind.

**work safely**



## SERVICE

Helpline service 24/7 Diagnosis, assistance and expert advice in case of any emergencies and questions regarding the use of the machines. We are there when you need us, whatever happens you have our support.

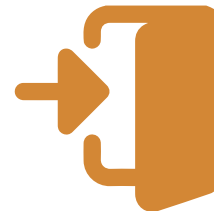

## AVAILABILITY

Online at all times.

enova 365



**work safely**



-  532 777 770
-  Aleja Wojska Polskiego 100,  
18-300 Zambrów
-  [facebook.com/InterTechZambrow](https://facebook.com/InterTechZambrow)
-  [intertech\\_agro](https://instagram.com/intertech_agro)
-  [InterTechAgro](https://www.youtube.com/InterTechAgro)
-  [sekretariat@intertech-agro.pl](mailto:sekretariat@intertech-agro.pl)
-  [www.intertech-agro.pl](http://www.intertech-agro.pl)



**work safely**





**work safely**



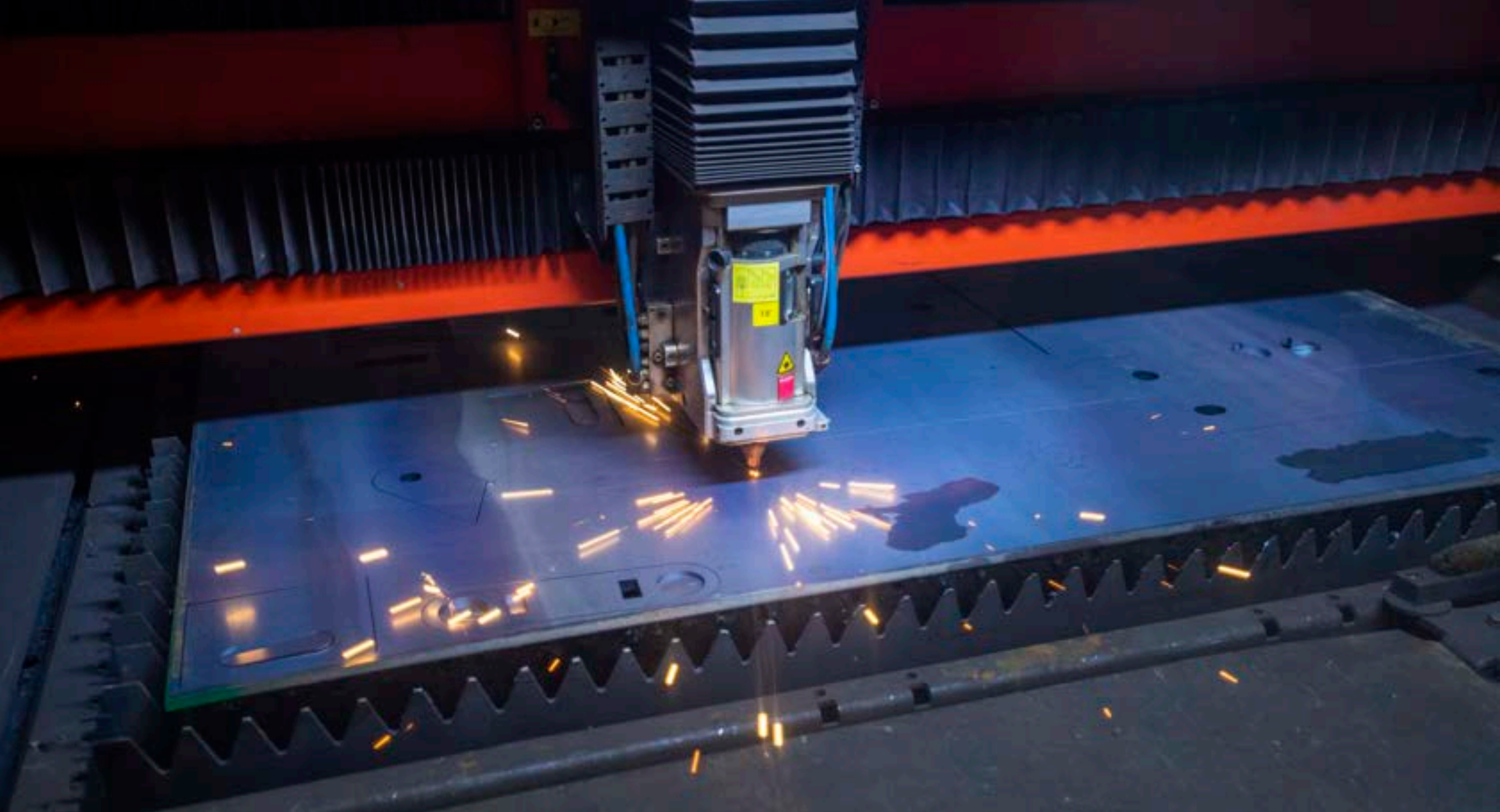

Catalogue valid as of 16/10/2023. Please quote name and catalogue number when ordering. The images in the catalogue may differ from the product on sale. The photos may include additional options which are not included in the standard equipment.

Inter Tech reserves the right to change technical parameters and other physical characteristics. Inter Tech reserves the right to make changes to the products without informing the customer. The weights given are approximate and may differ from the actual weight depending on equipment and configuration. The catalogue is for information purposes only and does not constitute a commercial offer within the meaning of Article 543 of the Civil Code. The General Terms and Conditions of Sale (GTS) are available on the Inter Tech website [www.intertech-agro.pl](http://www.intertech-agro.pl).

# Mission



Fusion of passion, knowledge, commitment in an ever-changing world.

# Vision



We are the company that best in agribusiness YESes care of relationships according to individual customer needs.



# Courage



- Boldness and openness
- Determination
- Commitment and passion for common goals

# Development



- Emphasis on innovation
- Development of skills and knowledge
- Searching for better and better solutions, meeting customers by constantly improving quality.

# Partnership



- Human First
- Building lasting relationships
- Commitment

We are intensively developing the sales segment and new products and services. We are adapting our business profile to be fully customer-focused. The values reflect the way Inter Tech wants to achieve its goals. The essence of the Human First partnership is customer focus, building lasting relationships and commitment. We actively increase the potential of new products through the fusion of modern contact channels and compatible services. Development means an emphasis on innovation, development of skills and knowledge and the search for ever better solutions, meeting customers by constantly improving quality. Courage means boldness and openness, determination as well as commitment and passion in achieving common goals. The combination of these values leads to a better understanding of customer expectations, allows us to respond to market challenges and strengthens the Inter Tech Family's corporate culture.

# Inter Tech Family

A fusion of passion, knowledge, commitment in an ever-changing world.

We have nothing to hide. Inter Tech is more than a company.

It is a community where everyone is treated like a family member.

There are few family businesses that build a lasting foundation in international relationships having a significant impact on agricultural development.

Inter Tech Family is the ideal place for ambitious, enthusiastic people looking for inspiration in their development, for whom gaining professional experience is a great motivation for work and a source of satisfaction.

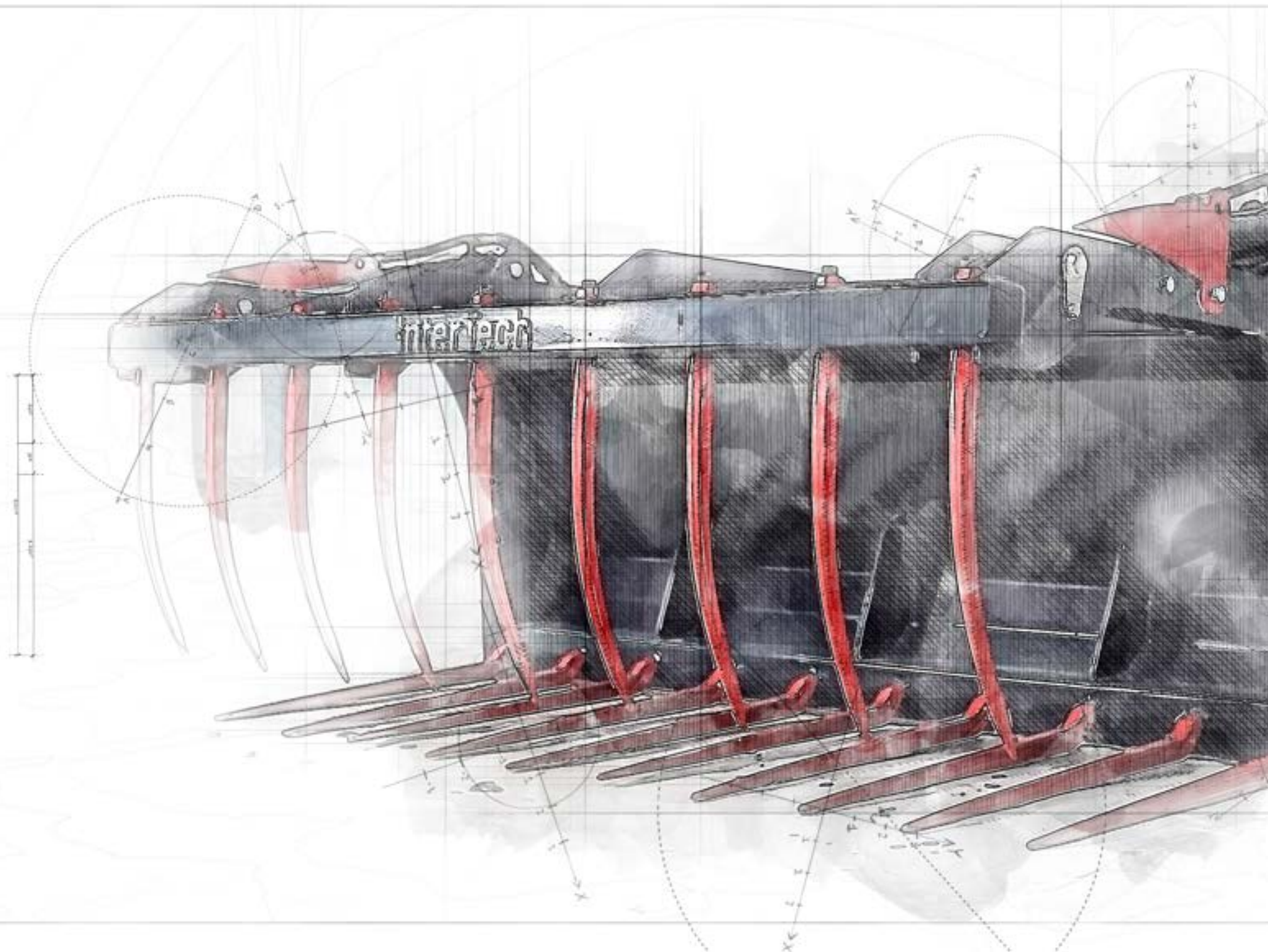

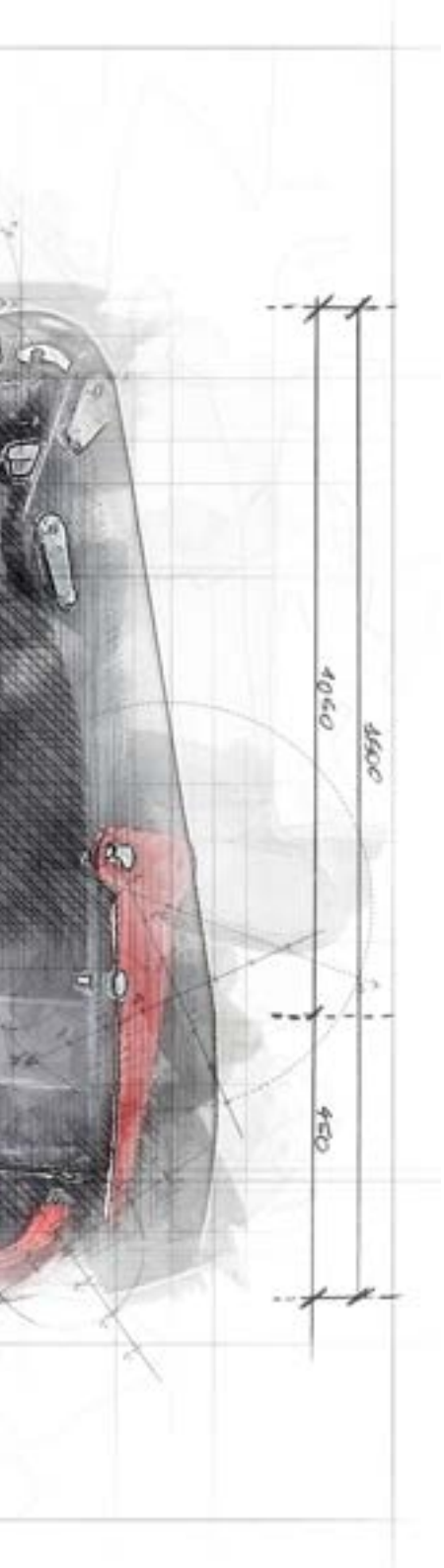

# Smart Line

Smart means diverse

We are aware of the difficult and unpredictable conditions in which farmers work.

Time and precision of action play a key role in managing farms. The quantity and diversity of daily tasks mean that they often need reliable equipment to increase the efficiency of their work.

The choice of accompanying machines that they can make will improve and facilitate their work.





Intertek

CONTAINERS

**Perfect in every inch**

# CONTAINERS

High-loading containers are perfect for all kinds of work where there is a need to transport small loads. Thanks to the hydraulic tipping mechanism, it is easy to unload grain, sand, or other bulk materials. Specially designed locks ensure safety in use.

The containers can be mounted at the rear or front of the tractor on a three-point suspension system. Due to their design, they can also function as a counterbalance. They are adapted to work with a front loader or loaders.

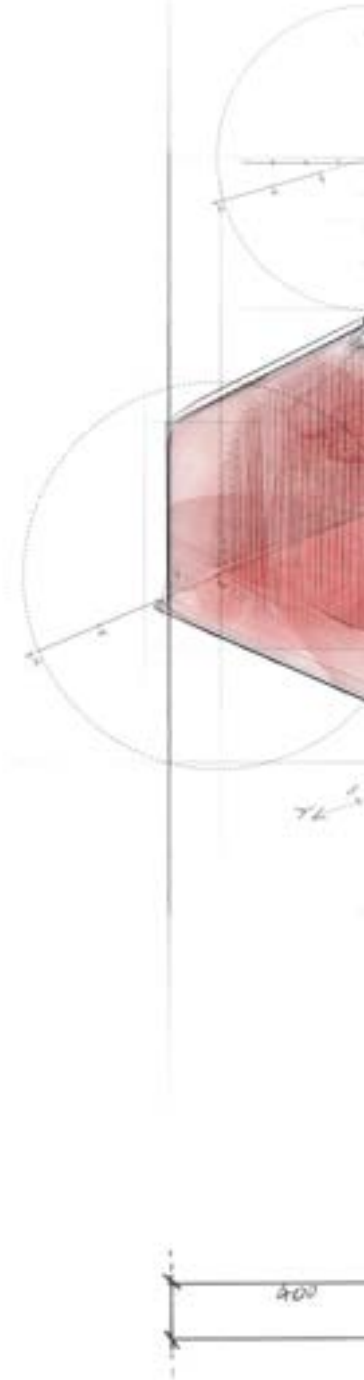

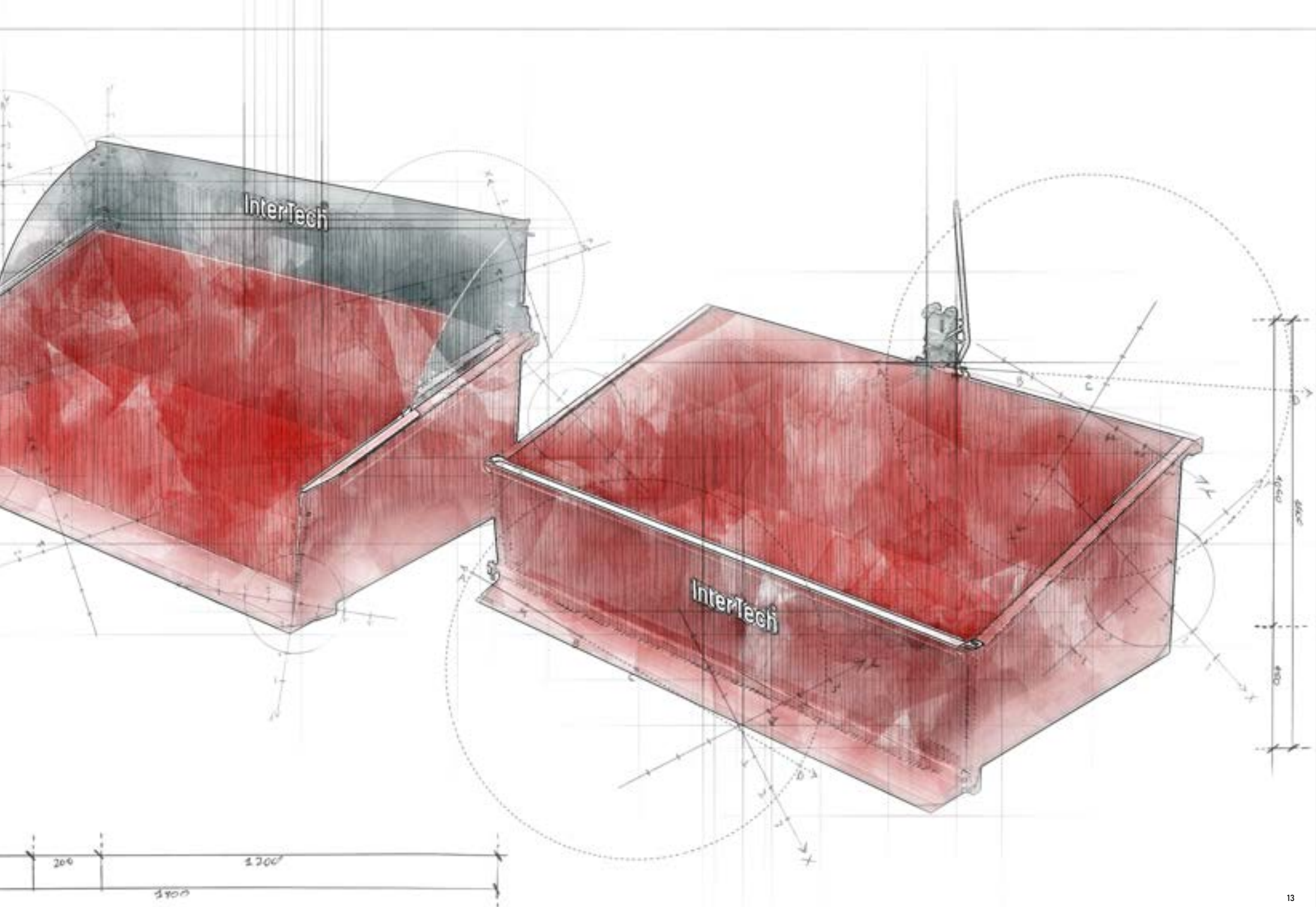



## MECHANICAL REAR CONTAINER

Machine no	SS01	SS02	SS03	SS04	SS05
Width (m)	1,2	1,4	1,6	1,8	2,0
Capacity (m <sup>3</sup> )	0,65	0,75	0,85	1,0	1,1
Weight (kg)	190	205	220	235	250
Equipment					
TUZ connection	✓	✓	✓	✓	✓
Service package (PLN)	● ●	● ●	● ●	● ●	● ●



## LIGHT HYDRAULIC REAR CONTAINER

Machine no	SS06	SS07	SS08
Width (m)	1,6	1,8	2,0
Capacity (m <sup>3</sup> )	0,95	1,05	1,15
Number of cylinders (pcs.)	1	1	2
Weight (kg)	345	360	375
Equipment			
TUZ connection	✓	✓	✓
EURO/TUZ connection (PLN)	●	●	●
Service package (PLN)	● ●	● ●	● ●

# SMART

line

High-capacity dual-cylinder system

Strong frame made of thick-walled pipes

Pivoting hatch to increase cargo capacity

Specially designed locks to guarantee safety of use



Robust design with a high payload capacity

## HYDRAULIC REAR CONTAINER

Machine no	SS09	SS10	SS11	SS12	SS13
Width (m)	1,6	1,8	2,0	2,2	2,4
Capacity (m <sup>3</sup> )	1,00	1,15	1,25	1,35	1,50
Number of cylinders (pcs.)	2	2	2	2	2
Weight (kg)	480	500	520	540	560
Equipment					
EURO/TUZ connection (PLN)	✓	✓	✓	✓	✓
Service package (PLN)	● ●	● ●	● ●	● ●	● ●

- ✓ Standard equipment
- Optional equipment
- Option not available
- Recommended
- Especially recommended



BALE GRIPPER

**Multifunctionality and precision**



# BALE GRIPPER

Bale grippers are used in the transport, sorting, loading, and unloading of wood, waste paper, bales of silage, hay, and straw. Thanks to the thoughtful design, the transfer of a single bale is non-invasive to the others. Bale grippers have appropriately curved arms ensuring the proper compression of the bales, as well as safe and long-lasting operation.

Grippers with tines, depending on the number of tines, can transfer even two bales at once, which shortens the work time in the field. Wood grippers are used for the safe and quick transport, loading, unloading, and sorting of wood. All grapples are compatible with front loaders or loaders.



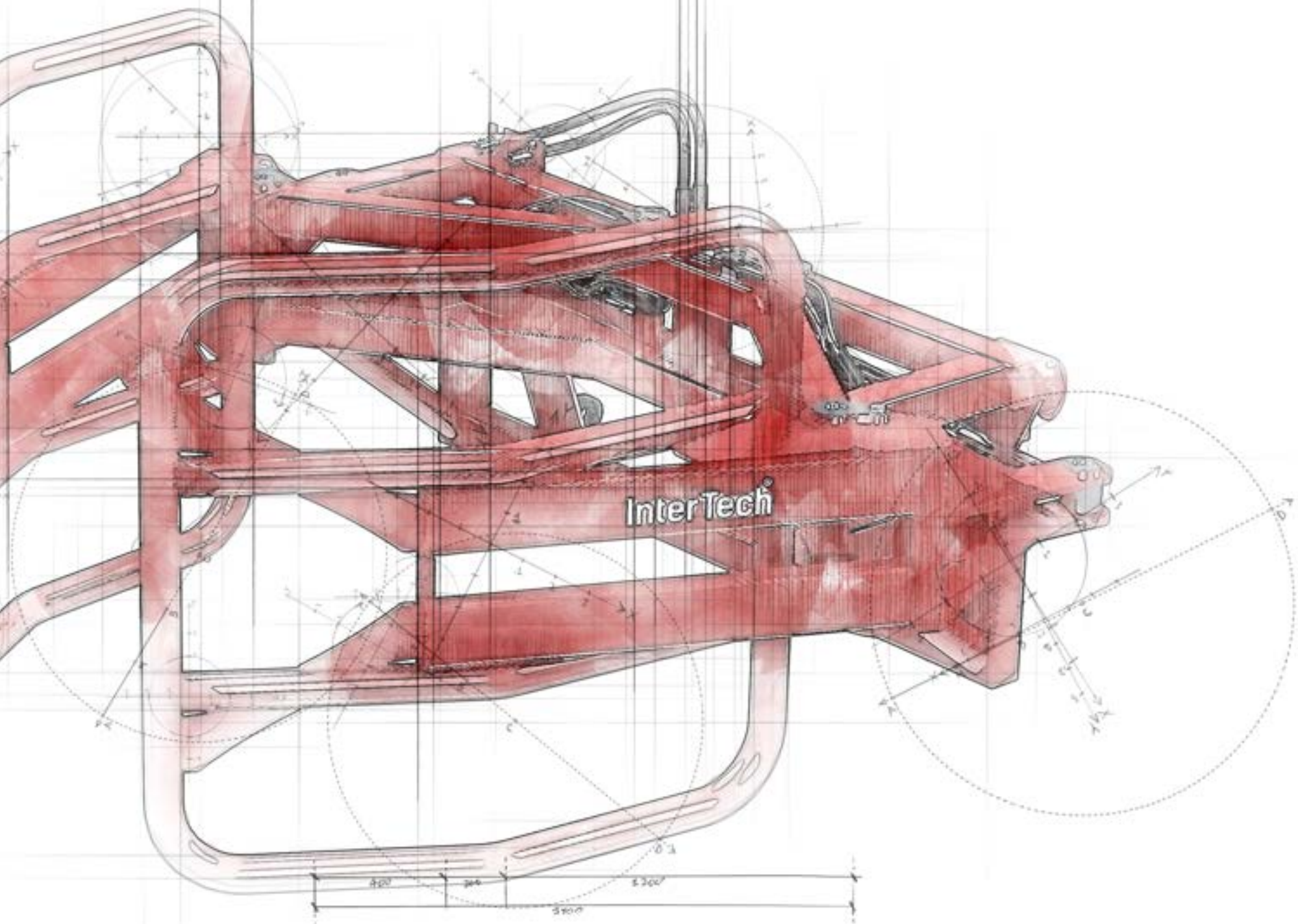



## BALE GRIPPER 1.2/1

Machine no	SC01
Bale size (mm)	1200
Load capacity (kg)	700
Number of cylinders (pcs.)	1
Weight (kg)	201
<b>Equipment</b>	
EURO or SMS connection	✓
Telehandler mount	—
Skid steer mount (PLN)	●
Hydraulic lock supporting the 3rd section (PLN)	●
Service package (PLN)	● ●



## BALE GRIPPER 1.2/2

Machine no	SC02
Bale size (mm)	1200
Load capacity (kg)	700
Number of cylinders (pcs.)	2
Weight (kg)	173
<b>Equipment</b>	
EURO or SMS connection	✓
Telehandler mount	—
Skid steer mount (PLN)	●
Hydraulic lock supporting the 3rd section (PLN)	●
Service package (PLN)	● ●

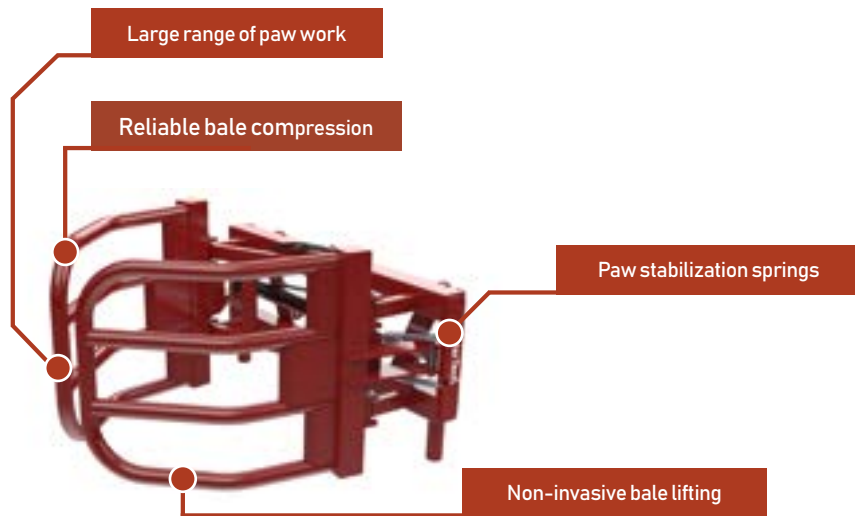

**SMART**  
line



## BALE GRIPPER LARGE

Machine no	SC03
Bale size (mm)	1200-1800
Load capacity (kg)	1000
Number of cylinders (pcs.)	1
Weight (kg)	256
<b>Equipment</b>	
EURO or SMS connection	✓
Telehandler mount	●
Skid steer mount (PLN)	●
Hydraulic lock supporting the 3rd section (PLN)	●
Service package (PLN)	● ●

## BALE GRIPPER RECTANGULAR IT 01

Machine no	SC04
Bale size (mm)	995-2000
Load capacity (kg)	700
Number of cylinders (pcs.)	2
Weight (kg)	250
<b>Equipment</b>	
EURO or SMS connection	✓
Telehandler mount	●
Skid steer mount (PLN)	●
Hydraulic lock supporting the 3rd section (PLN)	●
Service package (PLN)	● ●

- ✓ Standard equipment
- Optional equipment
- Option not available
- Recommended
- Especially recommended



## BALE GRIPPER WITH TINES

Machine no	SC05
Bale size (mm)	1200 – 1 bela
Number of tines (pcs.)	8
Load capacity (kg)	900
Number of cylinders (pcs.)	1
Weight (kg)	240
<b>Equipment</b>	
EURO or SMS connection	✓
Telehandler mount	●
Skid steer mount (PLN)	●
Hydraulic lock supporting the 3rd section (PLN)	●
Service package (PLN)	● ●



## BALE GRIPPER WITH TINES HD

Machine no	SC06
Bale size (mm)	1200 – 2 bele
Number of tines (pcs.)	8/2
Load capacity (kg)	1800
Number of cylinders (pcs.)	1
Weight (kg)	300
<b>Equipment</b>	
EURO or SMS connection	✓
Telehandler mount	●
Skid steer mount (PLN)	—
Hydraulic lock supporting the 3rd section (PLN)	●
Service package (PLN)	● ●

# SMART

line



## WOOD GRIPPER

Machine no	SC07
Opening height (mm)	0-820
Load capacity (kg)	700
Number of cylinders (pcs.)	2
Weight (kg)	300
<b>Equipment</b>	
EURO or SMS connection	✓
Telehandler mount	●
Skid steer mount (PLN)	●
Hydraulic lock supporting the 3rd section (PLN)	●
Service package (PLN)	● ●



## WOOD ARM FOR PALLET FORK

Machine no	SC08
Opening height (mm)	0-820
Number of cylinders (pcs.)	1
Weight (kg)	50
<b>Equipment</b>	
2A cat. connection	✓
3A cat. connection (PLN)	●
Service package (PLN)	● ●

- ✓ Standard equipment
- Optional equipment
- Option not available
- Recommended
- Especially recommended

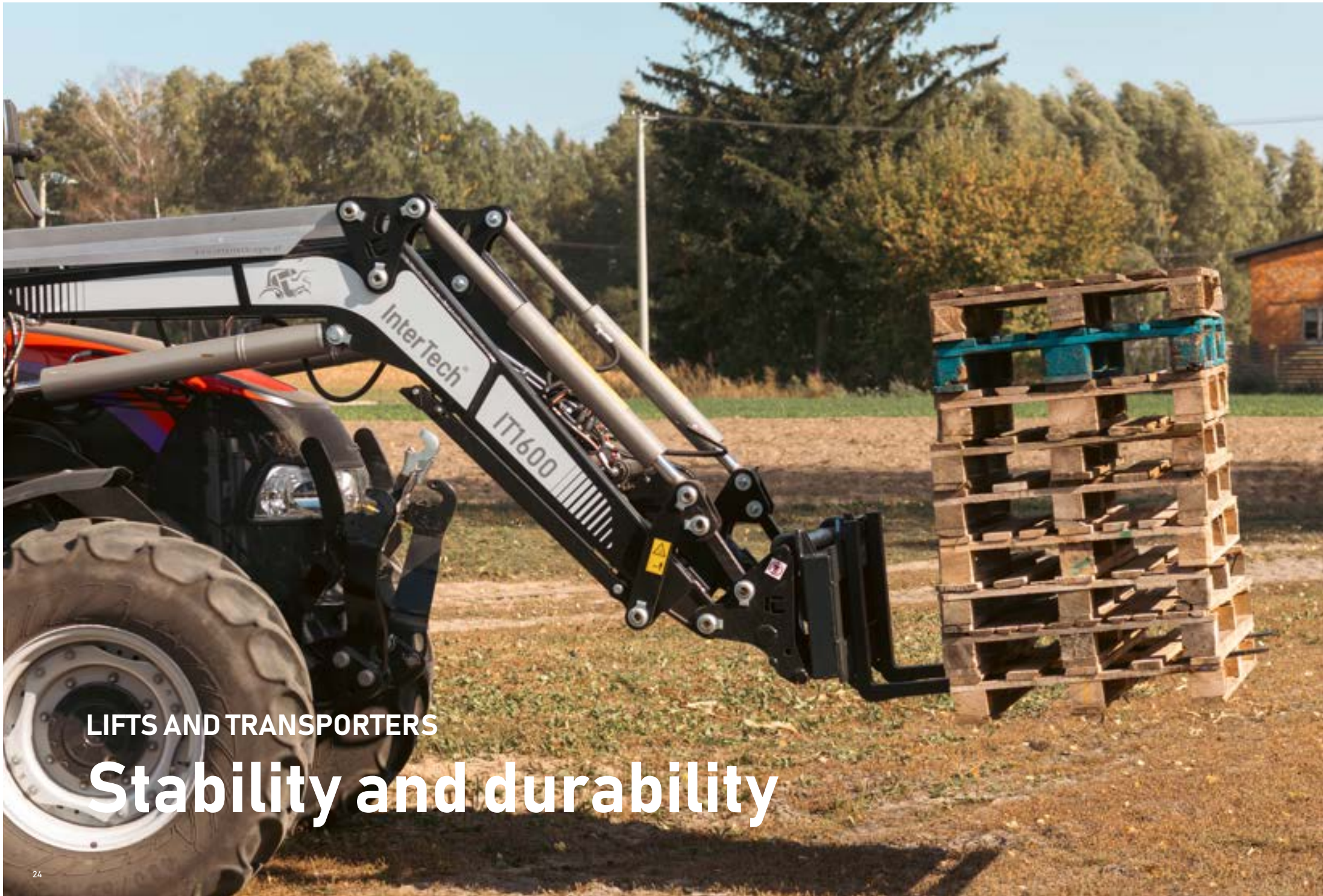

LIFTS AND TRANSPORTERS

**Stability and durability**



# LIFTS AND TRANSPORTERS

Lifts and transporters are used in loading, unloading, and transporting bales of silage, hay, straw, as well as various types of materials placed on carrying pallets and in big bag type sacks. Their application streamlines work by ensuring reliability. They are adapted for use with front loaders and loaders.

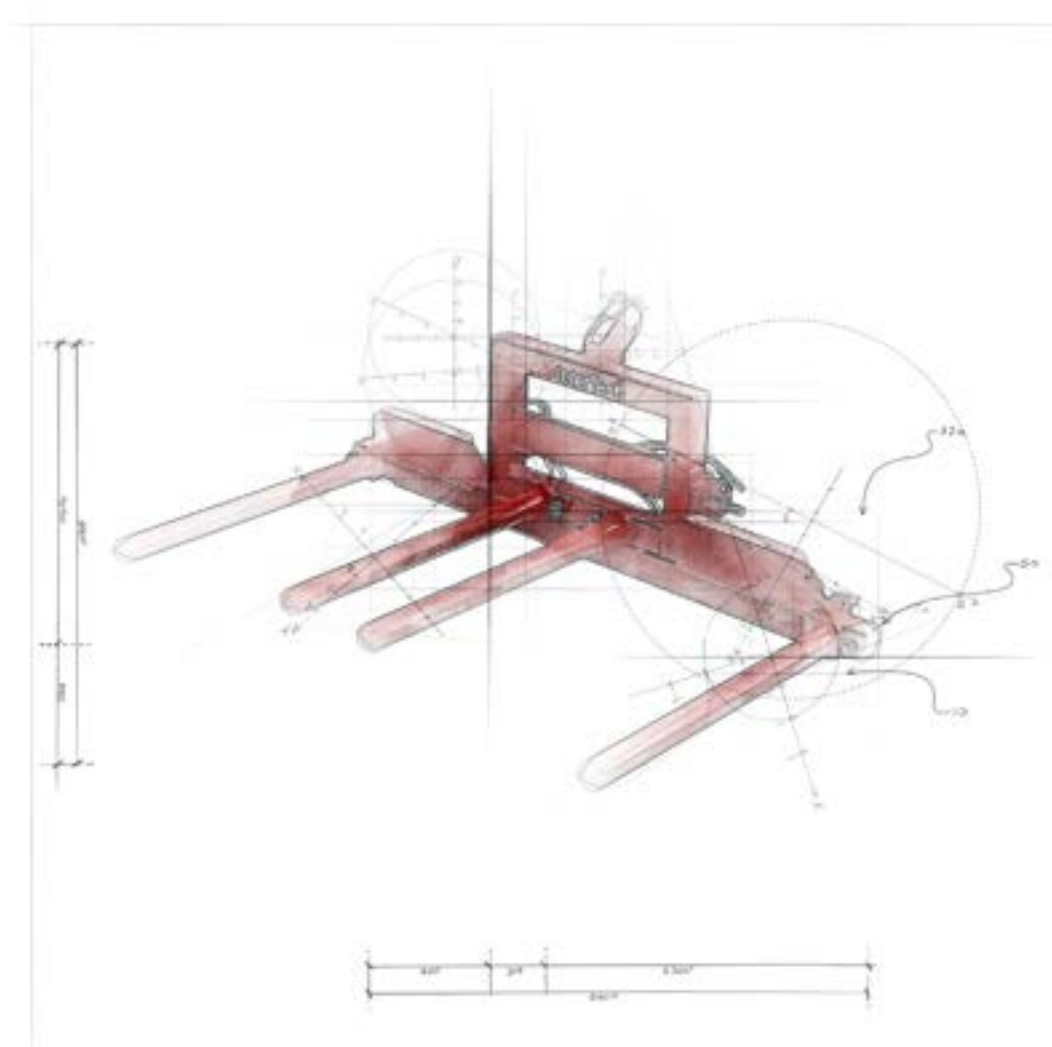

# SMART

line



## SINGLE HYDRAULIC BALE LIFT

Machine no	SPB01
Width (mm)	1200
Arm length (mm)	1250
Number of tines (pcs.)	2/2
Load capacity (kg)	700
Weight (kg)	185

Equipment	
EURO or SMS connection lub TUZ	✓
Telehandler mount	●
Skid steer mount (PLN)	●
Service package (PLN)	● ●



## DOUBLE HYDRAULIC BALE LIFT

Machine no	SPB02
Width (mm)	2400
Arm length (mm)	1250
Number of tines (pcs.)	4/4
Load capacity (kg)	1400
Weight (kg)	280

Equipment	
EURO or SMS connection lub TUZ	✓
Telehandler mount	●
Skid steer mount (PLN)	—
Service package (PLN)	● ●

- ✓ Standard equipment
- Optional equipment
- Option not available
- Recommended
- Especially recommended



## SINGLE MECHANICAL BALE LIFT

Machine no	SPB03
Width (mm)	1100
Arm length (mm)	1250
Number of tines (pcs.)	0/2
Load capacity (kg)	700
Weight (kg)	104
<b>Equipment</b>	
EURO or SMS connection lub TUZ	✓
Telehandler mount	●
Skid steer mount (PLN)	●
Service package (PLN)	● ●



## DOUBLE MECHANICAL BALE LIFT

Machine no	SPB04
Width (mm)	2100
Arm length (mm)	1250
Number of tines (pcs.)	0/4
Load capacity (kg)	1400
Weight (kg)	165
<b>Equipment</b>	
EURO or SMS connection lub TUZ	✓
Telehandler mount	●
Skid steer mount (PLN)	●
Service package (PLN)	● ●

# SMART

line



## BALE TRANSPORTER

Machine no	ST01	ST02	ST03	ST04
Number of tines (pcs.)	2	3	4	6
Load capacity (kg)	700	700	1500	1500
Number of bales (pcs.)	1	1	2	2
Weight (kg)	40	40	55	55
Equipment				
EURO or SMS connection	✓	✓	✓	✓
Telehandler mount	—	—	●	●
Skid steer mount (PLN)	●	●	—	—
Service package (PLN)	● ●	● ●	● ●	● ●



## BALE TRANSPORTER FOR PALLET FORK

Machine no	ST05
Load capacity (kg)	350
Weight (kg)	11
Equipment	
Zine 1100 (mm)	✓
2A cat. connection	✓
3A cat. connection (PLN)	●
Service package (PLN)	● ●

- ✓ Standard equipment
- Optional equipment
- Option not available
- Recommended
- Especially recommended

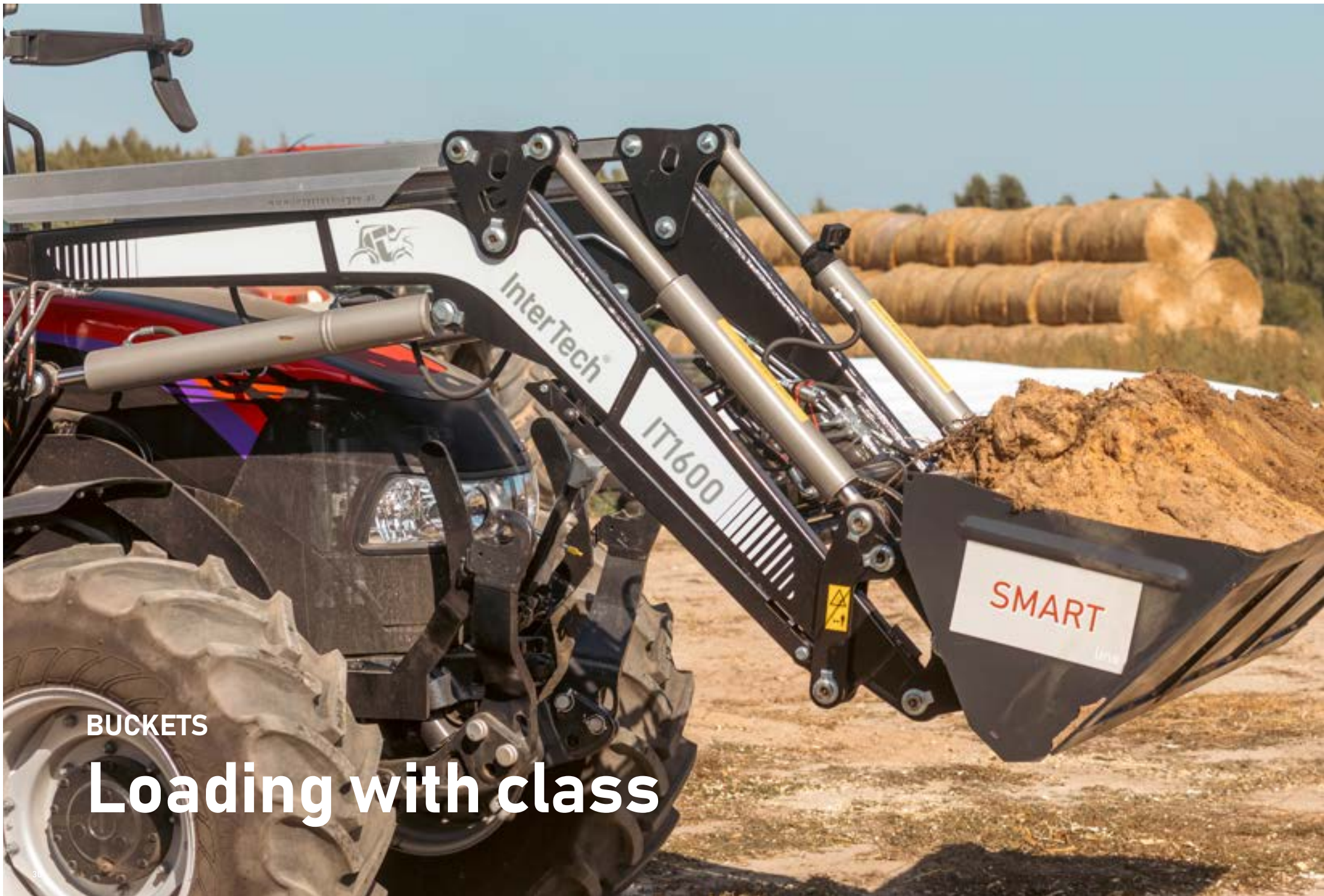

BUCKETS

**Loading with class**



# BUCKETS

The buckets are designed for tasks related to the loading, unloading, and transport of bulk materials such as soil, stones, agricultural products, fertilizers, etc. They are characterized by stability and exceptional durability due to the use of suitable components and perfectly executed welds.

Depending on their size and purpose, they can be attached to front loaders, telescopic loaders, or mini loaders. They will perform well both on farms and construction sites.

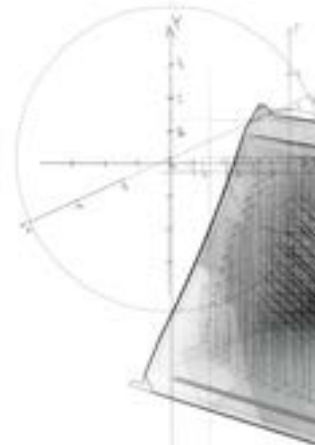

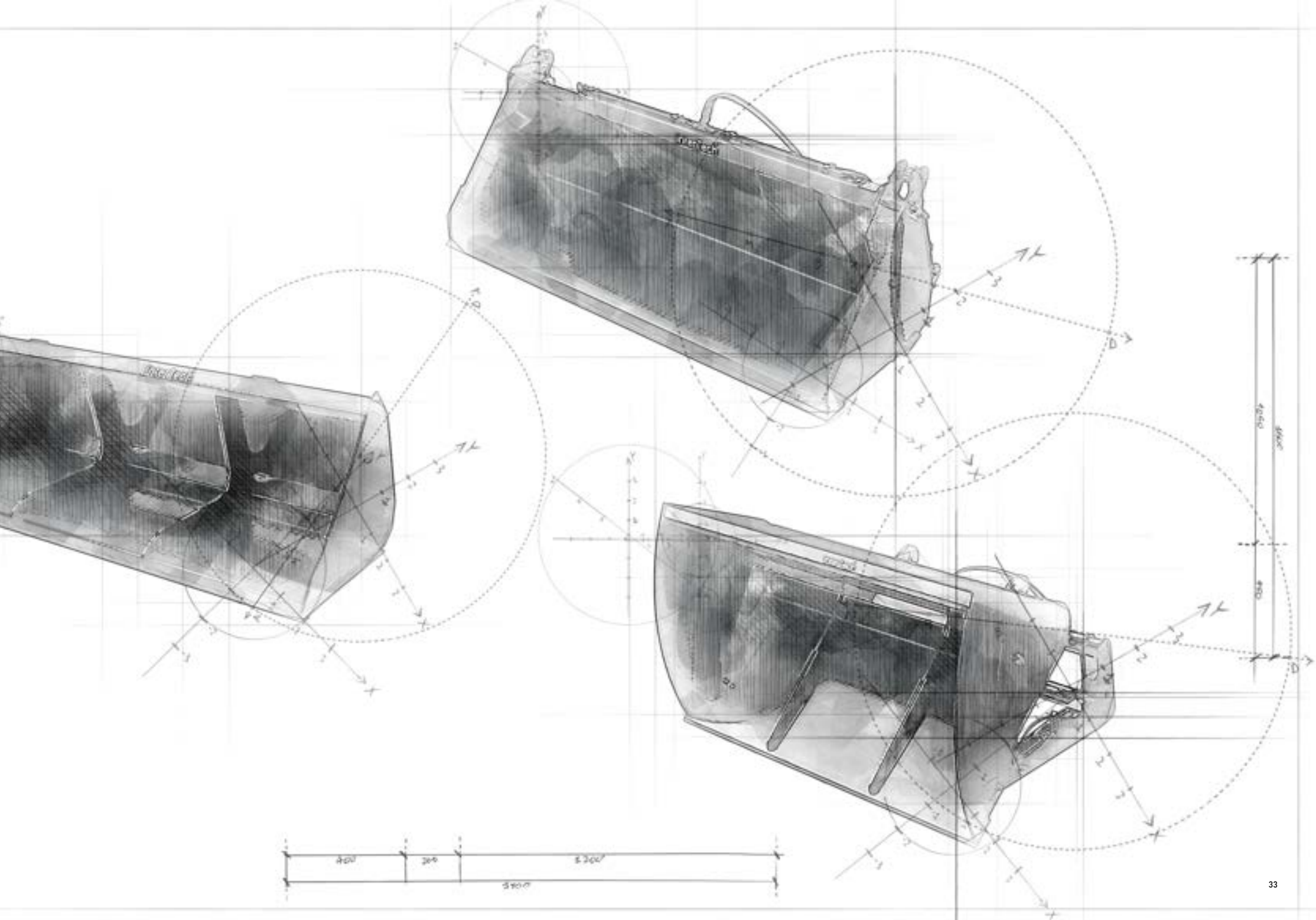



## TRAPEZOIDAL BUCKET

Machine no	SL01	SL02	SL03	SL04	SL05
Width (m)	1,5	1,8	2,0	2,2	2,4
Capacity (m <sup>3</sup> )	0,36	0,43	0,48	0,53	0,58
Weight (kg)	149	167	179	198	220
Equipment					
EURO or SMS connection	✓	✓	✓	✓	✓
Telehandler mount	—	—	—	—	—
Skid steer mount (PLN)	●	●	●	●	●
Service package (PLN)	●●	●●	●●	●●	●●



## TRAPEZOIDAL BUCKET HD

Machine no	SL06	SL07	SL08	SL09	SL10
Width (m)	1,5	1,8	2,0	2,2	2,4
Capacity (m <sup>3</sup> )	0,38	0,45	0,50	0,56	0,61
Weight (kg)	175	200	220	235	255
Equipment					
EURO or SMS connection	✓	✓	✓	✓	✓
Telehandler mount	●	●	●	●	●
Skid steer mount (PLN)	●	●	●	●	●
Service package (PLN)	●●	●●	●●	●●	●●

# SMART

line



## VOLUMETRIC BUCKET

Machine no	SL11	SL12	SL13	SL14
Width (m)	1,8	2,0	2,2	2,4
Capacity (m <sup>3</sup> )	0,70	0,78	0,86	0,94
Weight (kg)	269	295	321	358
Equipment				
EURO or SMS connection	✓	✓	✓	✓
Telehandler mount	—	—	●	●
Skid steer mount (PLN)	●	●	—	—
Service package (PLN)	● ●	● ●	● ●	● ●

- ✓ Standard equipment
- Optional equipment
- Option not available
- Recommended
- Especially recommended



## DVD BUCKET

Machine no	SL15	SL16	SL17	SL18	SL19
Width (m)	1,6	1,8	2,0	2,2	2,4
Capacity (m <sup>3</sup> )	0,62	0,70	0,78	0,85	0,93
Weight (kg)	210	230	260	280	305
Equipment					
EURO or SMS connection	✓	✓	✓	✓	✓
Telehandler mount	●	●	●	●	●
Skid steer mount (PLN)	●	●	—	—	—
Service package (PLN)	● ●	● ●	● ●	● ●	● ●



## TELEHANDLER VOLUMETRIC BUCKET

Machine no	SL20	SL21	SL22
Width (m)	2,0	2,2	2,4
Capacity (m <sup>3</sup> )	1,45	1,60	1,75
Weight (kg)	550	580	600
Equipment			
EURO or SMS connection	—	—	—
Telehandler mount (PLN)	✓	✓	✓
Skid steer mount (PLN)	—	—	—
Service package (PLN)	● ●	● ●	● ●

# SMART

line



## TELEHANDLER VOLUMETRIC BUCKET XXL

Machine no	SL23	SL24	SL25
Width (m)	2.0	2.2	2.4
Capacity (m <sup>3</sup> )	2.0	2.20	2.40
Weight (kg)	845	890	935
Equipment			
EURO or SMS connection	—	—	—
Telehandler mount	✓	✓	✓
Skid steer mount (PLN)	—	—	—
Service package (PLN)	● ●	● ●	● ●

- ✓ Standard equipment
- Optional equipment
- Option not available
- Recommended
- Especially recommended



## AV BUCKET FOR LIGHT MATERIALS

Machine no	SL26	SL27	SL28	SL29
Width (m)	1,05	1,2	1,3	1,6
Capacity (m <sup>3</sup> )	0,33	0,40	0,42	0,51
Weight (kg)	110	130	140	170
Equipment				
EURO or SMS connection	—	—	—	—
Telehandler mount	—	—	—	—
Skid steer mount (PLN)	✓	✓	✓	✓
Service package (PLN)	● ●	● ●	● ●	● ●



## UNIVERSAL BUCKET MINI

Machine no	SL30	SL31	SL32	SL33	SL34
Width (m)	0,9	1,0	1,2	1,3	1,4
Capacity (m <sup>3</sup> )	0,35	0,40	0,50	0,54	0,59
Weight (kg)	143	150	161	173	181
Equipment					
EURO or SMS connection	—	—	—	—	—
Telehandler mount	—	—	—	—	—
Skid steer mount (PLN)	✓	✓	✓	✓	✓
Service package (PLN)	● ●	● ●	● ●	● ●	● ●

# SMART

line



## AV 4IN1 BUCKET

Machine no	SL35	SL36	SL37	SL38	SL39
Width (m)	1,1	1,2	1,3	1,4	1,6
Capacity (m <sup>3</sup> )	0,15	0,17	0,18	0,20	0,24
Opening height (mm)	160	160	160	160	160
Weight (kg)	180	190	200	210	225
Equipment					
AVANT mount	✓	✓	✓	✓	✓
EURO or SMS connection	—	—	—	—	—
Telehandler mount	—	—	—	—	—
Skid steer mount (PLN)	✓	✓	✓	✓	✓
Service package (PLN)	● ●	● ●	● ●	● ●	● ●

- ✓ Standard equipment
- Optional equipment
- Option not available
- Recommended
- Especially recommended



## CONSTRUCTION 4IN1 BUCKET

Machine no	SL40	SL41	SL42	SL43	SL44
Width (m)	1,6	1,8	2,0	2,2	2,4
Capacity (m <sup>3</sup> )	0,42	0,47	0,53	0,59	0,64
Opening height (mm)	650	650	650	650	650
Weight (kg)	355	405	450	500	540
Equipment					
EURO or SMS connection	✓	✓	✓	✓	✓
Telehandler mount	—	●	●	●	●
Skid steer mount (PLN)	●	—	—	—	—
Hydraulic lock supporting the 3rd section (PLN)	●	●	●	●	●
Service package (PLN)	● ●	● ●	● ●	● ●	● ●



## HIGH LOADING BUCKET

Machine no	SL45	SL46	SL47	SL48
Width (m)	1,6	1,8	2,0	2,2
Capacity (m <sup>3</sup> )	0,60	0,70	0,80	0,90
Weight (kg)	430	470	520	547
Equipment				
EURO or SMS connection	✓	✓	✓	✓
Telehandler mount	●	●	●	●
Skid steer mount (PLN)	●	—	—	—
Hydraulic lock supporting the 3rd section (PLN)	●	●	●	●
Service package (PLN)	● ●	● ●	● ●	● ●



## HIGH LOADING BUCKET XXL

Machine no	SL49	SL50
Width (m)	2,8	3,0
Capacity (m <sup>3</sup> )	3,15	3,40
Weight (kg)	1460	1550
Equipment		
EURO or SMS connection	—	—
Telehandler mount	✓	✓
Skid steer mount (PLN)	—	—
Hydraulic lock supporting the 3rd section (PLN)	●	●
Service package (PLN)	●●	●●

- ✓ Standard equipment
- Optional equipment
- Option not available
- Recommended
- Especially recommended



SILAGE CUTTERS

**Reach for more**



# SILAGE CUTTERS

Silage cutters are used for extracting silage directly from the stack. The proper design ensures that its structure is not compromised during the process, which allows the fermentation to proceed correctly, and the cut surface remains smooth.

Moreover, the even material intake with optimal pressure is ensured by the cooperation of two cylinders with a lock that supports the third section.

The range also includes a bale cutter used to cut bales of silage or straw. Its solidly made teeth guarantee a long service life while reducing the risk of damage.

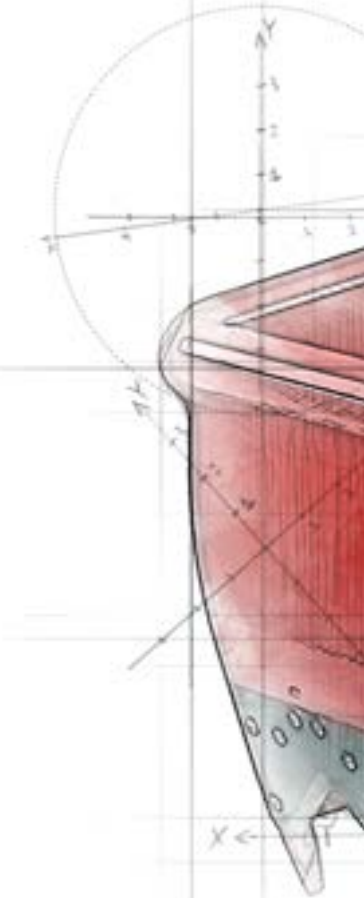

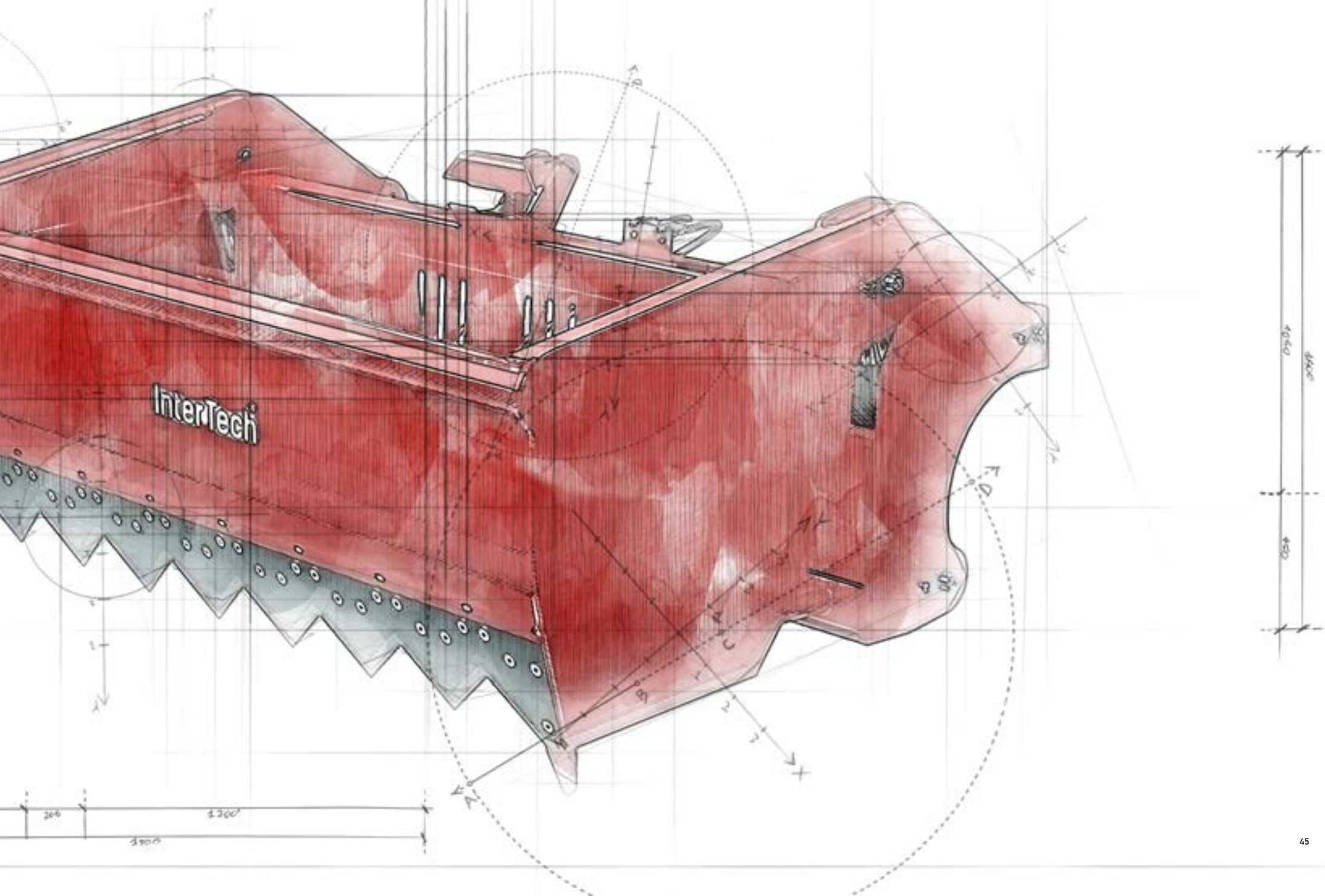



## SILLAGE CUTTER „ALIGATOR”

Machine no	SW01	SW02
Width (m)	1,4	1,6
Capacity (m <sup>3</sup> )	0,95	1,10
Opening height (mm)	940	940
Number of cylinders (pcs.)	2	2
Weight (kg)	630	700
Equipment		
EURO or SMS connection	✓	✓
Telehandler mount (PLN)	—	●
Skid steer mount (PLN)	—	—
Hydraulic lock supporting the 3rd section (PLN)	●	●
Service package (PLN)	● ●	● ●



## SILLAGE CUTTER

Machine no	SW03
Width (m)	1,6
Capacity (m <sup>3</sup> )	1,05
Opening height (mm)	1340
Number of cylinders (pcs.)	2
Weight (kg)	648
Equipment	
EURO or SMS connection	✓
Telehandler mount (PLN)	●
Skid steer mount (PLN)	—
Hydraulic lock supporting the 3rd section (PLN)	●
Service package (PLN)	● ●



## BALE CUTTER

Machine no	SW04
Width (m)	1,6
Capacity (m <sup>3</sup> )	0,5
Opening height (mm)	1300
Number of cylinders (pcs.)	2
Weight (kg)	540
<b>Equipment</b>	
EURO or SMS connection	✓
Telehandler mount (PLN)	●
Skid steer mount (PLN)	●
Hydraulic lock supporting the 3rd section (PLN)	●
Service package (PLN)	● ●

- ✓ Standard equipment
- Optional equipment
- Option not available
- Recommended
- Especially recommended





GRAB BUCKET

**Efficiency without loss**

# GRAB BUCKET

Grab buckets are designed for the transport of manure, corn, and other materials with small fractions that need support from below over the entire surface.

The spillage of transported material is minimized thanks to the screwed-on sides, and their appropriate design guarantees safety and comfort of work. The conical shape of the grab buckets allows for filling and emptying without loss. The right pressing force is provided by properly selected hydraulic cylinders.



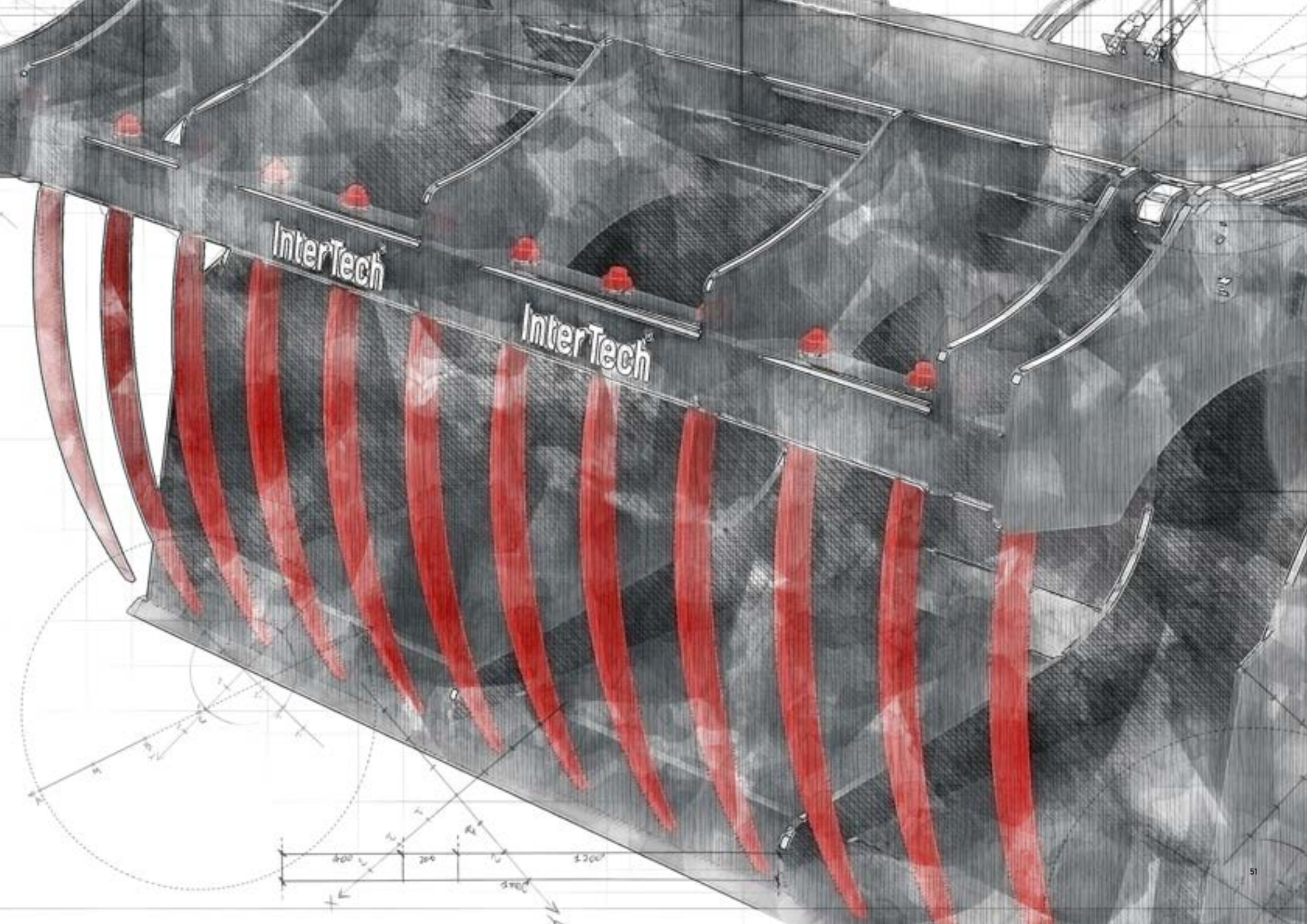

InterTech<sup>®</sup>

InterTech<sup>®</sup>

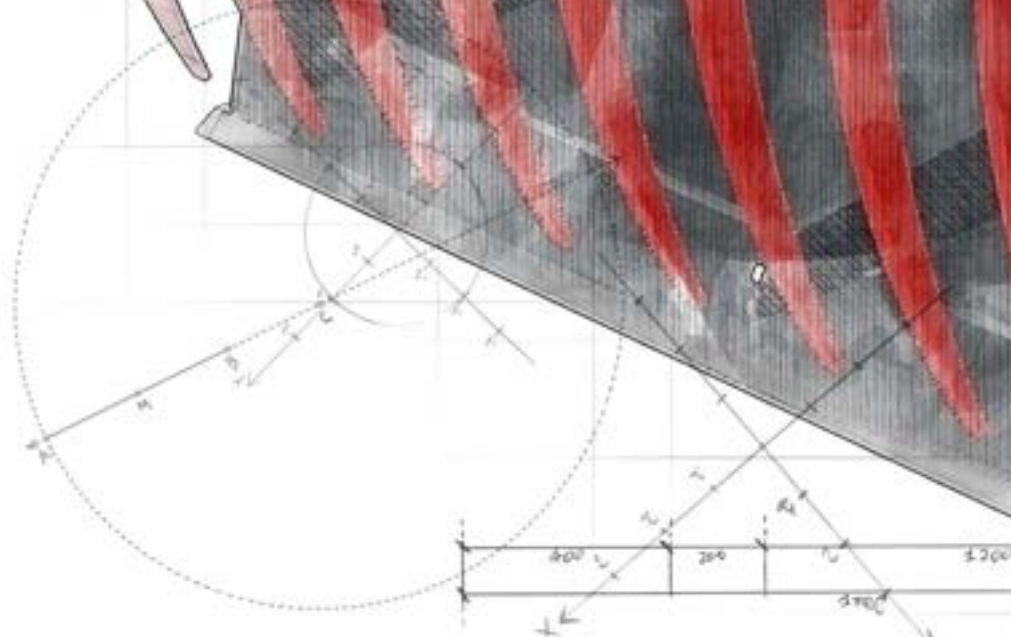



## GRAB BUCKET FORGED TINE

Machine no	SLK01	SLK02	SLK03	SLK04	SLK05
Width (m)	1,5	1,8	2,0	2,2	2,4
Capacity (m <sup>3</sup> )	0,75	0,90	1,0	1,1	1,2
Opening height (mm)	1000	1000	1000	1000	1000
Number of cylinders (pcs.)	2	2	2	2	2
Weight (kg)	285	381	406	430	460
Equipment					
EURO or SMS connection	✓	✓	✓	✓	✓
Telehandler mount (PLN)	—	—	●	●	●
Skid steer mount (PLN)	●	●	—	—	—
Service package (PLN)	● ●	● ●	● ●	● ●	● ●

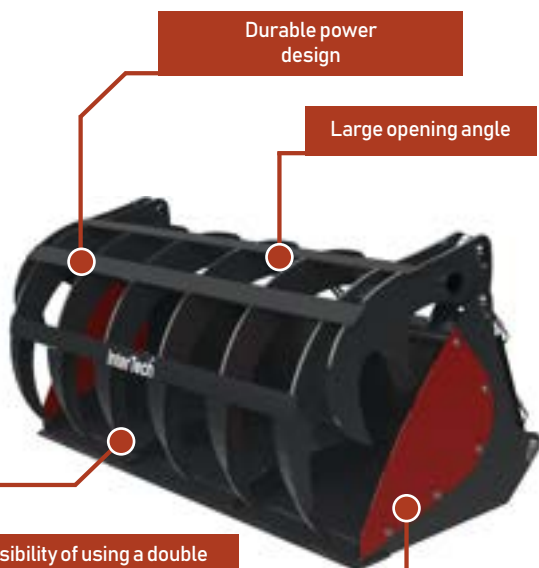

Durable power design

Large opening angle

Possibility of using a double blade

Possibility of disassembling the side walls

## GRAB BUCKET BURNED TINE

Machine no	SLK06	SLK07	SLK08	SLK09	SLK10
Width (m)	1,5	1,8	2,0	2,2	2,4
Capacity (m <sup>3</sup> )	0,66	0,78	0,88	0,97	1,06
Opening height (mm)	1500	1500	1500	1500	1500
Number of cylinders (pcs.)	2	2	2	2	2
Weight (kg)	391	504	550	571	593
Equipment					
EURO or SMS connection	✓	✓	✓	✓	✓
Telehandler mount (PLN)	●	●	●	●	●
Skid steer mount (PLN)	●	●	—	—	—
Service package (PLN)	● ●	● ●	● ●	● ●	● ●

# SMART

line



## GRAB BUCKET AV

Machine no	SLK11	SLK12	SLK13
Width (m)	1,2	1,3	1,4
Capacity (m <sup>3</sup> )	0,30	0,33	0,36
Opening height (mm)	810	810	810
Number of cylinders (pcs.)	1	1	1
Weight (kg)	160	175	185
Equipment			
AVANT mount	✓	✓	✓
EURO or SMS connection	—	—	—
Telehandler mount (PLN)	—	—	—
Skid steer mount (PLN)	✓	✓	✓
Service package (PLN)	● ●	● ●	● ●

- ✓ Standard equipment
- Optional equipment
- Option not available
- Recommended
- Especially recommended



## GRAB BUCKET TELEHANDLERS

Machine no	SLK14	SLK15	SLK16
Width (m)	2,0	2,2	2,4
Capacity (m <sup>3</sup> )	1,48	1,63	1,78
Opening height (mm)	1530	1530	1530
Number of cylinders (pcs.)	2	2	2
Weight (kg)	810	830	845
Equipment			
EURO or SMS connection	—	—	—
Telehandler mount (PLN)	✓	✓	✓
Skid steer mount (PLN)	—	—	—
Hydraulic lock supporting the 3rd section (PLN)	●	●	●
Service package (PLN)	● ●	● ●	● ●



## GRAB BUCKET MULTI-GRAB

Machine no	SLK17	SLK18	SLK19
Width (m)	2,0	2,2	2,4
Capacity (m <sup>3</sup> )	1,05	1,15	1,26
Opening height (mm)	1650	1650	1650
Number of cylinders (pcs.)	2	2	2
Weight (kg)	710	750	790
Equipment			
EURO or SMS connection	—	—	—
Telehandler mount (PLN)	✓	✓	✓
Skid steer mount (PLN)	—	—	—
Hydraulic lock supporting the 3rd section (PLN)	●	●	●
Service package (PLN)	● ●	● ●	● ●

# SMART

line



## GRAB BUCKET MULTI

Machine no	SLK20	SLK21	SLK22
Width (m)	2,0	2,2	2,4
Capacity (m <sup>3</sup> )	0,88	0,92	1,01
Opening height (mm)	1380	1380	1380
Number of cylinders (pcs.)	2	2	2
Weight (kg)	680	710	740
Equipment			
EURO or SMS connection	—	—	—
Telehandler mount (PLN)	✓	✓	✓
Skid steer mount (PLN)	—	—	—
Hydraulic lock supporting the 3rd section (PLN)	●	●	●
Service package (PLN)	● ●	● ●	● ●

- ✓ Standard equipment
- Optional equipment
- Option not available
- Recommended
- Especially recommended





GRAB AND FORKS

**Power and  
strength combined**

# GRAB AND FORKS

Forks and grabs are dedicated to transporting manure, silage, or corn, among other materials.

Depending on the model, the angle of opening of the movable frame varies, as well as the possibility of aggregation with loaders and stackers. The rear wall prevents material from falling out during transport.

The proper selection of cylinders guarantees a secure grip of the jaws, while the sturdy frame ensures stability and confidence during transport.



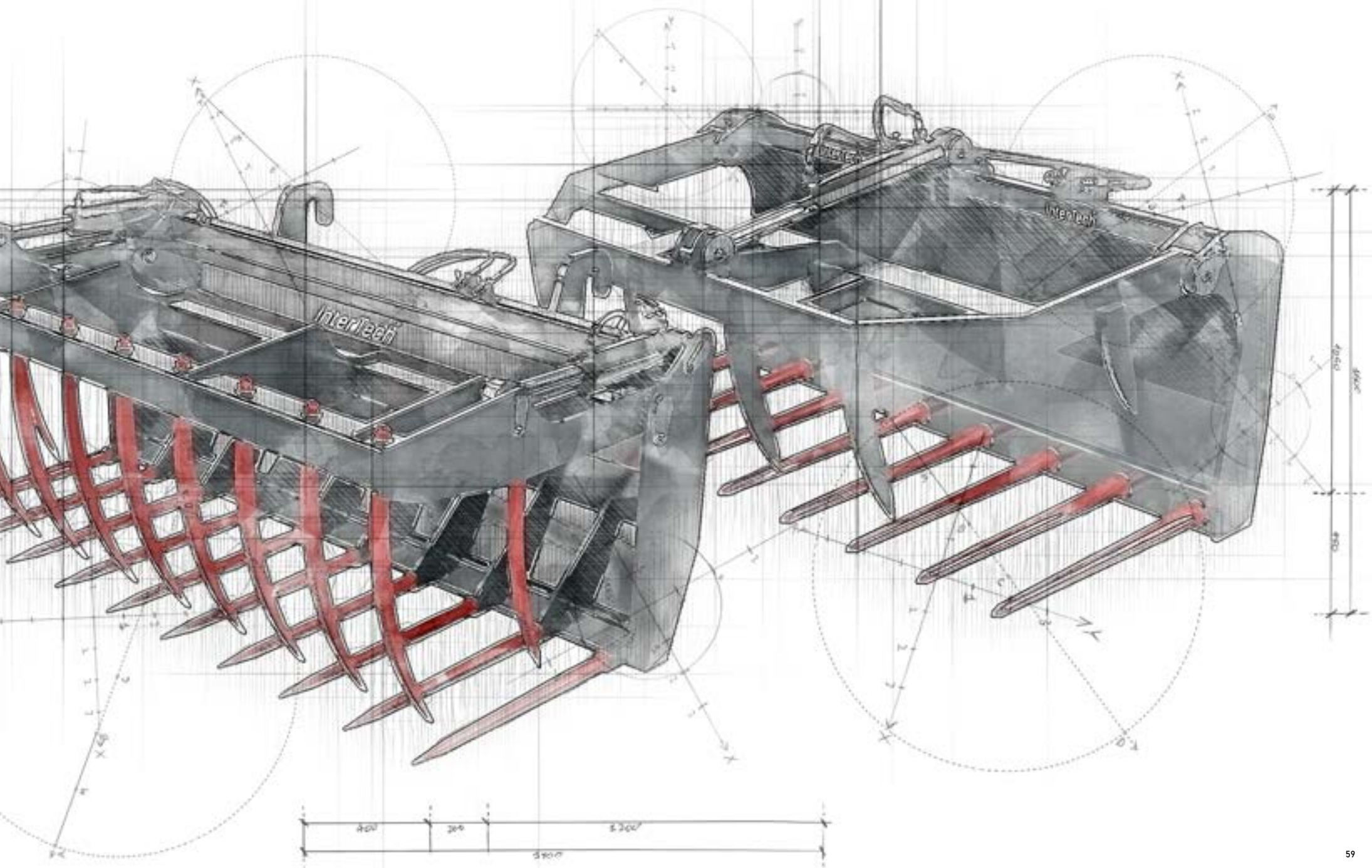



## GRAB IT2

Machine no	SWK01	SWK02	SWK03	SWK04	SWK05	SWK06	SWK07
Width (m)	1,2	1,3	1,5	1,8	2,0	2,2	2,4
Capacity (m <sup>3</sup> )	0,82	0,87	1	1,13	1,26	1,38	1,51
Opening height (mm)	1210	1210	1210	1210	1210	1210	1210
Load capacity (kg)	500	600	700	800	900	1000	1100
Number of cylinders (pcs.)	2	2	2	2	2	2	2
Weight (kg)	170	200	235	285	325	365	405
Equipment							
EURO or SMS connection	✓	✓	✓	✓	✓	✓	✓
Telehandler mount (PLN)	—	—	●	●	●	●	●
Skid steer mount (PLN)	●	●	●	●	—	—	—
Service package (PLN)	●●	●●	●●	●●	●●	●●	●●



## GRAB IT2 HD

Machine no	SWK08	SWK09	SWK10	SWK11	SWK12
Width (m)	1,5	1,8	2,0	2,2	2,4
Capacity (m <sup>3</sup> )	1	1,14	1,27	1,4	1,53
Opening height (mm)	1170	1170	1170	1170	1170
Load capacity (kg)	700	800	900	1000	1100
Number of cylinders (pcs.)	2	2	2	2	2
Weight (kg)	260	290	340	370	400
Equipment					
EURO or SMS connection	✓	✓	✓	✓	✓
Telehandler mount (PLN)	●	●	●	●	●
Skid steer mount (PLN)	●	●	—	—	—
Service package (PLN)	●●	●●	●●	●●	●●



## MANURE FORK IT1

Machine no	SWK13	SWK14	SWK15	SWK16
Width (m)	1.2	1.5	1.8	2.0
Load capacity (kg)	600	700	800	900
Weight (kg)	125	143	158	173
Equipment				
EURO or SMS connection	✓	✓	✓	✓
Telehandler mount (PLN)	—	—	●	●
Skid steer mount (PLN)	●	●	●	●
Service package (PLN)	●●	●●	●●	●●

- ✓ Standard equipment
- Optional equipment
- Option not available
- Recommended
- Especially recommended



## MANURE FORK IT1

Machine no	SWK17	SWK18	SWK19	SWK20
Width (m)	1,2	1,5	1,8	2,0
Load capacity (kg)	600	700	800	900
Weight (kg)	137	152	167	182
Equipment				
EURO or SMS connection	✓	✓	✓	✓
Telehandler mount (PLN)	—	—	●	●
Skid steer mount (PLN)	●	●	●	●
Service package (PLN)	● ●	● ●	● ●	● ●



## TELEHANDLERS GRAB HD

Machine no	SWK21	SWK22	SWK23
Width (m)	2,0	2,2	2,4
Capacity (m <sup>3</sup> )	1,2	1,4	1,6
Opening height (mm)	1160	1160	1160
Number of cylinders (pcs.)	2	2	2
Weight (kg)	605	640	670
Equipment			
EURO or SMS connection	—	—	—
Telehandler mount (PLN)	✓	✓	✓
Skid steer mount (PLN)	—	—	—
Hydraulic lock supporting the 3rd section (PLN)	●	●	●
Service package (PLN)	● ●	● ●	● ●

# SMART

line



## AV MINI GRAB

Machine no	SWK24	SWK25	SWK26	SWK27
Width (m)	1,1	1,2	1,3	1,4
Capacity (m <sup>3</sup> )	0,24	0,26	0,28	0,30
Opening height (mm)	840	840	840	840
Number of cylinders (pcs.)	1	1	1	1
Weight (kg)	150	160	175	185
Equipment				
EURO or SMS connection	—	—	—	—
Telehandler mount (PLN)	—	—	—	—
Skid steer mount (PLN)	✓	✓	✓	✓
Service package (PLN)	● ●	● ●	● ●	● ●

- ✓ Standard equipment
- Optional equipment
- Option not available
- Recommended
- Especially recommended



## GRAB MINI 01

Machine no	SWK28	SWK29	SWK30	SWK31
Width (m)	0,9	1,0	1,2	1,4
Capacity (m <sup>3</sup> )	0,30	0,35	0,42	0,50
Opening height (mm)	1070	1070	1070	1070
Number of cylinders (pcs.)	1	1	1	1
Weight (kg)	165	175	190	205
Equipment				
EURO or SMS connection	—	—	—	—
Telehandler mount (PLN)	—	—	—	—
Skid steer mount (PLN)	✓	✓	✓	✓
Service package (PLN)	● ●	● ●	● ●	● ●

# SMART

line



## GRAB MINI 02

Machine no	SWK32	SWK33	SWK34
Width (m)	1,1	1,3	1,5
Capacity (m <sup>3</sup> )	0,35	0,40	0,45
Opening height (mm)	840	840	840
Number of cylinders (pcs.)	2	2	2
Weight (kg)	190	215	230
Equipment			
EURO or SMS connection	—	—	—
Telehandler mount (PLN)	—	—	—
Skid steer mount (PLN)	✓	✓	✓
Service package (PLN)	● ●	● ●	● ●

- ✓ Standard equipment
- Optional equipment
- Option not available
- Recommended
- Especially recommended

# PALLET FORKS

Pallet forks are dedicated to the transport of materials stored on pallets. The ability to adjust the fork width means that they can be used for a much wider range of applications. The solid construction and precision manufacturing ensure that this product is highly durable.

The big bag lift eases the transport of materials commonly used in agriculture, such as feed, as well as semi-finished products in manufacturing plants.

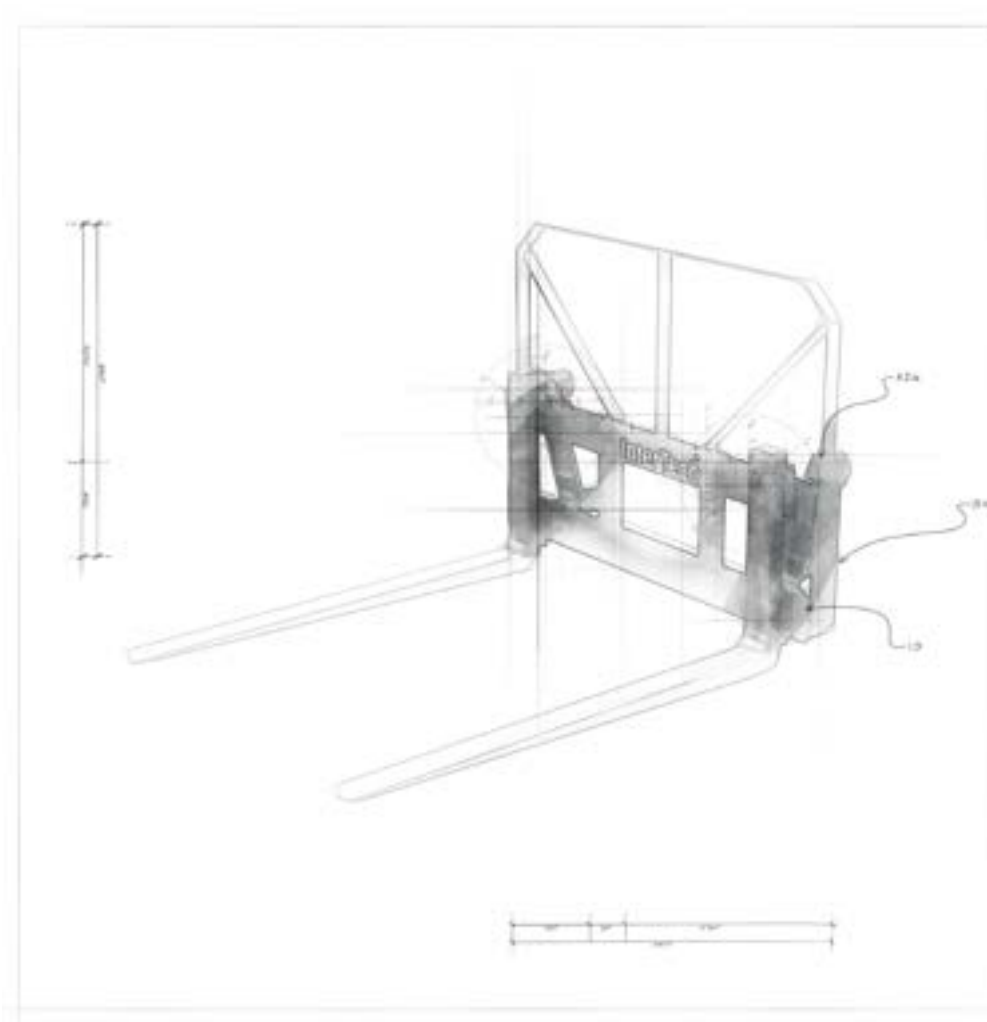

# SMART

line



## PALLET FORK IT

Machine no	SP01	SP02
Model	2A	3A
Fork dimensions (mm)	80/40/1200	100/45/1200
Load capacity (kg)	2000	3000
Weight (kg)	120	140
Equipment		
EURO or SMS connection	✓	—
Telehandler mount (PLN)	—	✓
Skid steer mount (PLN)	●	—
Sleeves for tines (PLN)	●	●
Service package (PLN)	●●	●●



## PALLET FORK IT WITH TOP EXTENSION

Machine no	SP03	SP04
Model	2A	3A
Fork dimensions (mm)	80/40/1200	100/45/1200
Load capacity (kg)	2000	3000
Weight (kg)	125	145
Equipment		
EURO or SMS connection	✓	—
Telehandler mount (PLN)	—	✓
Skid steer mount (PLN)	●	—
Sleeves for tines (PLN)	●	●
Service package (PLN)	●●	●●



## BIG BAG LIFT

Machine no	S103
Load capacity (kg)	1100
Weight (kg)	105
Equipment	
EURO or SMS connection	✓
Telehandler mount (PLN)	—
Skid steer mount (PLN)	●
Service package (PLN)	●●

- ✓ Standard equipment
- Optional equipment
- Option not available
- Recommended
- Especially recommended





REDUCTION

**Compatibility is fundamental**

# REDUCTION

Reductions allow for operation without the need for a front loader. They act as a connector, thanks to which equipment with different mountings can be aggregated effortlessly.

Their remarkable advantage is the availability and compatibility with practically every mounting on the market.

Additionally, thanks to the reducers, users who only have a three-point suspension system can use machines dedicated to front loaders.

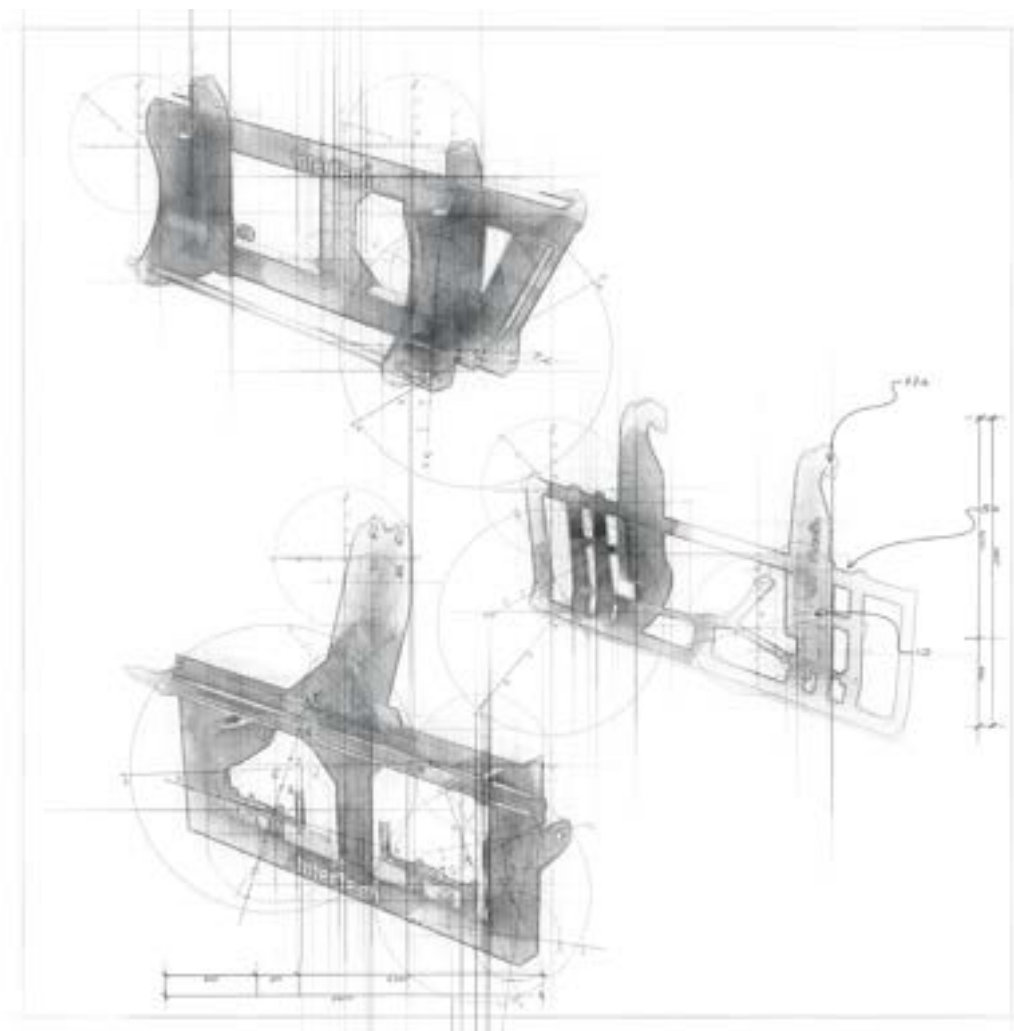

# SMART

line



## REDUCTION

Machine no	S106
Front loader <-> Front loader (PLN)	●
Front loader <-> Telehandler (PLN)	●
Front loader <-> Skid steer loader (PLN)	●
Telehandler <-> Telehandler (PLN)	●
Telehandler <-> Skid steer loader (PLN)	●
Skid steer loader <-> Skid steer loader (PLN)	●

- ✓ Standard equipment
- Optional equipment
- Option not available
- Recommended
- Especially recommended

# REMAINING EQUIPMENT

The excavator arm has a solid, steel construction that allows to perform earthworks. It is intended for use on mini loaders.

The manure scraper, on the other hand, facilitates maintaining cleanliness in the barn and reduces working time thanks to its wide working width.

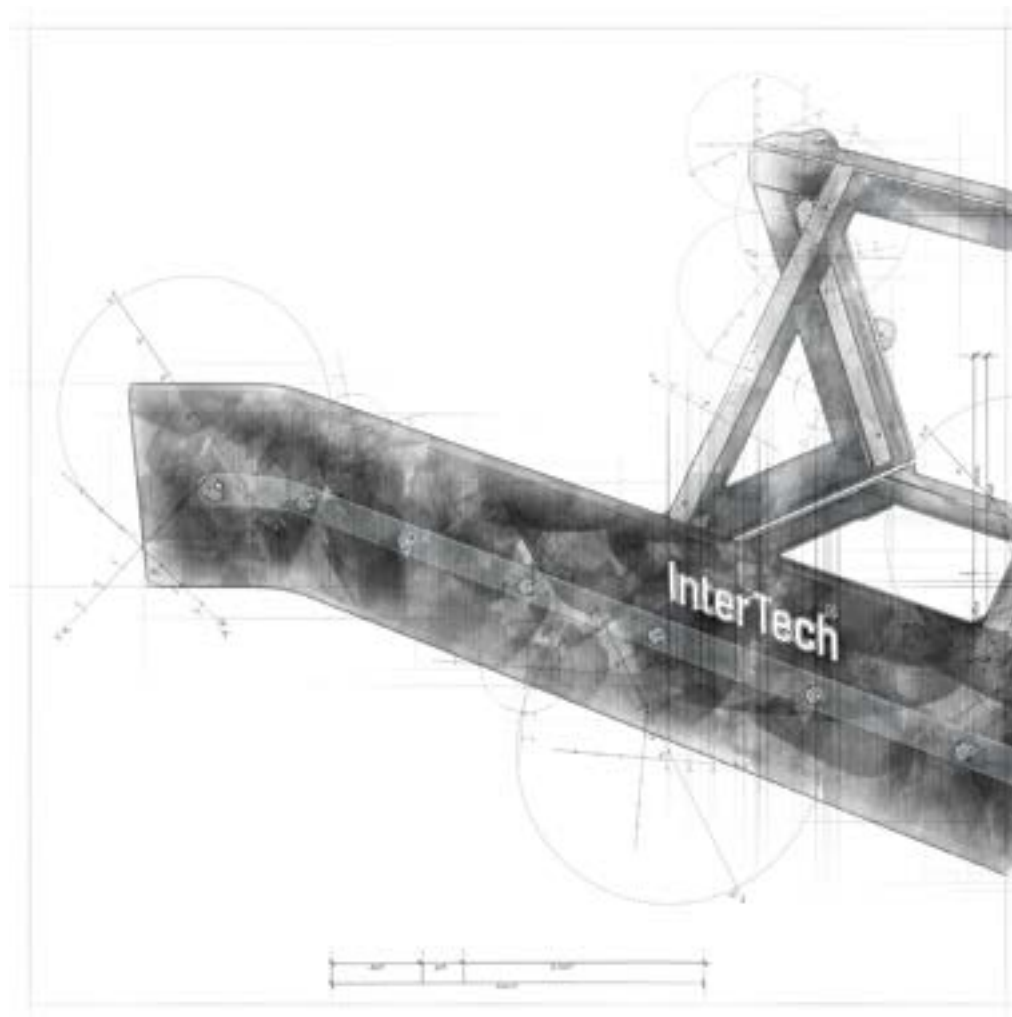

# SMART

line



## MANURE SCRAPER

Machine no	SI01	SI02
Width (m)	2.6	3.0
Height (m)	0.4	0.4
Weight (kg)	120	144
Equipment		
EURO or SMS connection lub TUZ kat. II	✓	✓
Telehandler mount (PLN)	●	●
Skid steer mount (PLN)	●	●
EURO/TUZ connection (PLN)	●	●
Service package (PLN)	● ●	● ●



## AV EXCAVATOR ARM

Machine no	SI04	SI05
Bucket width (cm)	25	40
Digging depth (m)	1.4	1.4
Weight (kg)	110	120
Equipment		
EURO or SMS connection	—	—
Telehandler mount	—	—
Skid steer mount (PLN)	✓	✓
Service package (PLN)	● ●	● ●

- ✓ Standard equipment
- Optional equipment
- Option not available
- Recommended
- Especially recommended

interfech



## GUARANTEE

We guarantee a professional service and professional advice. Every customer is important to us.



## ENVIRONMENT

We use renewable energy sources.



## TRANSPORT



We offer logistical support. Safe delivery of purchased machines.

[www.itlogistic.pl](http://www.itlogistic.pl)



## SAFETY

We build with your safety in mind.

**work safely**



## SERVICE

Helpline service 24/7 Diagnosis, assistance and expert advice in case of any emergencies and questions regarding the use of the machines. We are there when you need us, whatever happens you have our support.

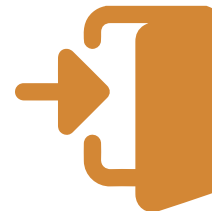

## AVAILABILITY



Online at all times.

enova 365



**work safely**



-  532 777 770
-  Aleja Wojska Polskiego 100,  
18-300 Zambrów
-  [facebook.com/InterTechZambrow](https://facebook.com/InterTechZambrow)
-  [intertech\\_agro](https://instagram.com/intertech_agro)
-  [InterTechAgro](https://www.youtube.com/InterTechAgro)
-  [sekretariat@intertech-agro.pl](mailto:sekretariat@intertech-agro.pl)
-  [www.intertech-agro.pl](http://www.intertech-agro.pl)



**work safely**





**work safely**





Catalogue valid as of 16/10/2023. Please quote name and catalogue number when ordering. The images in the catalogue may differ from the product on sale. The photos may include additional options which are not included in the standard equipment.

Inter Tech reserves the right to change technical parameters and other physical characteristics. Inter Tech reserves the right to make changes to the products without informing the customer. The weights given are approximate and may differ from the actual weight depending on equipment and configuration. The catalogue is for information purposes only and does not constitute a commercial offer within the meaning of Article 543 of the Civil Code. The General Terms and Conditions of Sale (GTS) are available on the Inter Tech website [www.intertech-agro.pl](http://www.intertech-agro.pl).

# Mission



Fusion of passion, knowledge, commitment in an ever-changing world.

# Vision



We are the company that best in agribusiness YESes care of relationships according to individual customer needs.



# Courage



- Boldness and openness
- Determination
- Commitment and passion for common goals

# Development



- Emphasis on innovation
- Development of skills and knowledge
- Searching for better and better solutions, meeting customers by constantly improving quality.

# Partnership



- Human First
- Building lasting relationships
- Commitment

We are intensively developing the sales segment and new products and services. We are adapting our business profile to be fully customer-focused. The values reflect the way Inter Tech wants to achieve its goals. The essence of the Human First partnership is customer focus, building lasting relationships and commitment. We actively increase the potential of new products through the fusion of modern contact channels and compatible services. Development means an emphasis on innovation, development of skills and knowledge and the search for ever better solutions, meeting customers by constantly improving quality. Courage means boldness and openness, determination as well as commitment and passion in achieving common goals. The combination of these values leads to a better understanding of customer expectations, allows us to respond to market challenges and strengthens the Inter Tech Family's corporate culture.

# Inter Tech Family

A fusion of passion, knowledge, commitment in an ever-changing world.

We have nothing to hide. Inter Tech is more than a company.

It is a community where everyone is treated like a family member.

There are few family businesses that build a lasting foundation in international relationships having a significant impact on agricultural development.

Inter Tech Family is the ideal place for ambitious, enthusiastic people looking for inspiration in their development, for whom gaining professional experience is a great motivation for work and a source of satisfaction.

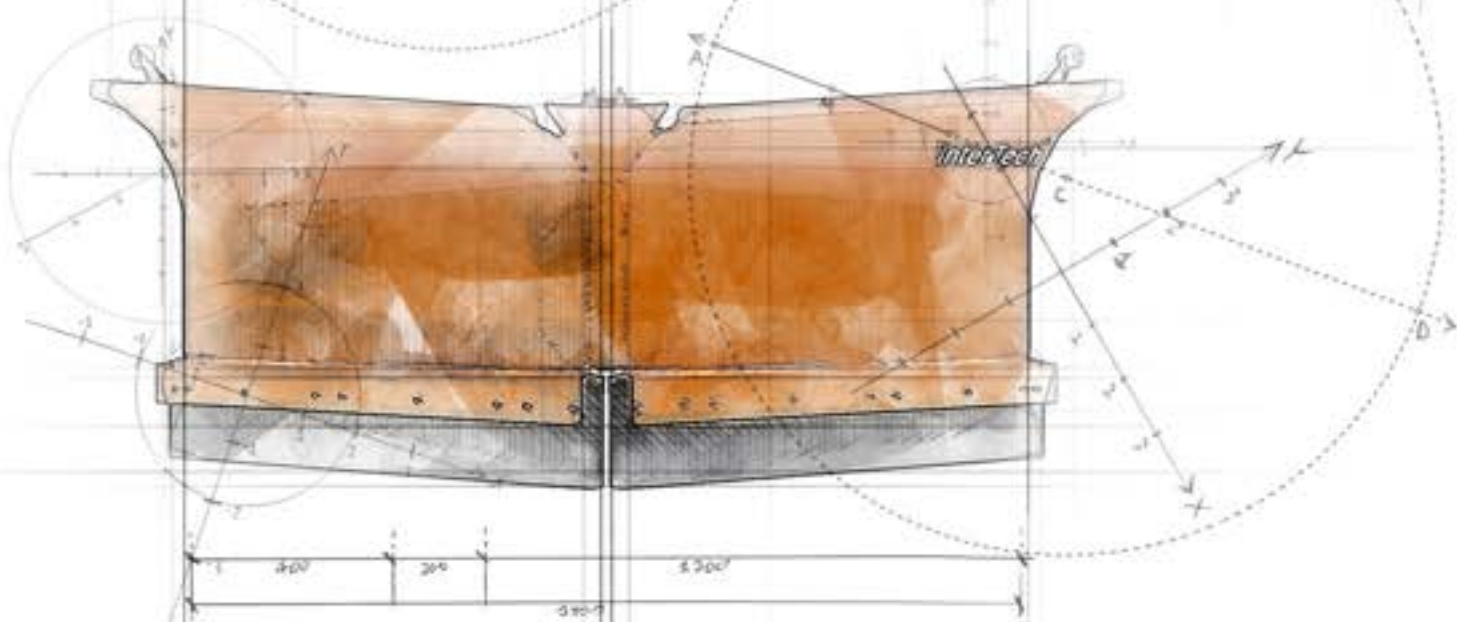
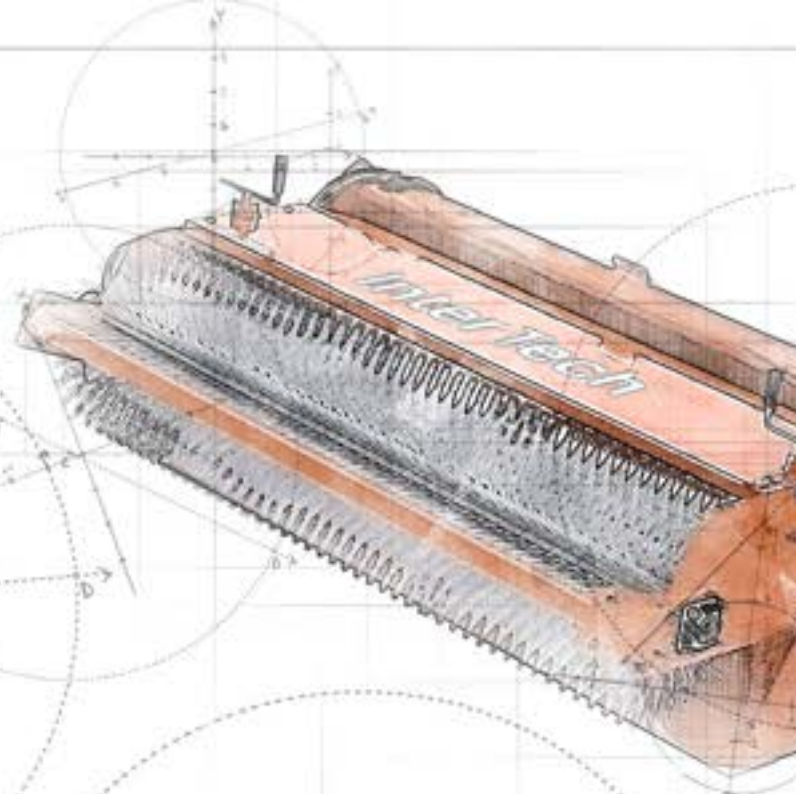
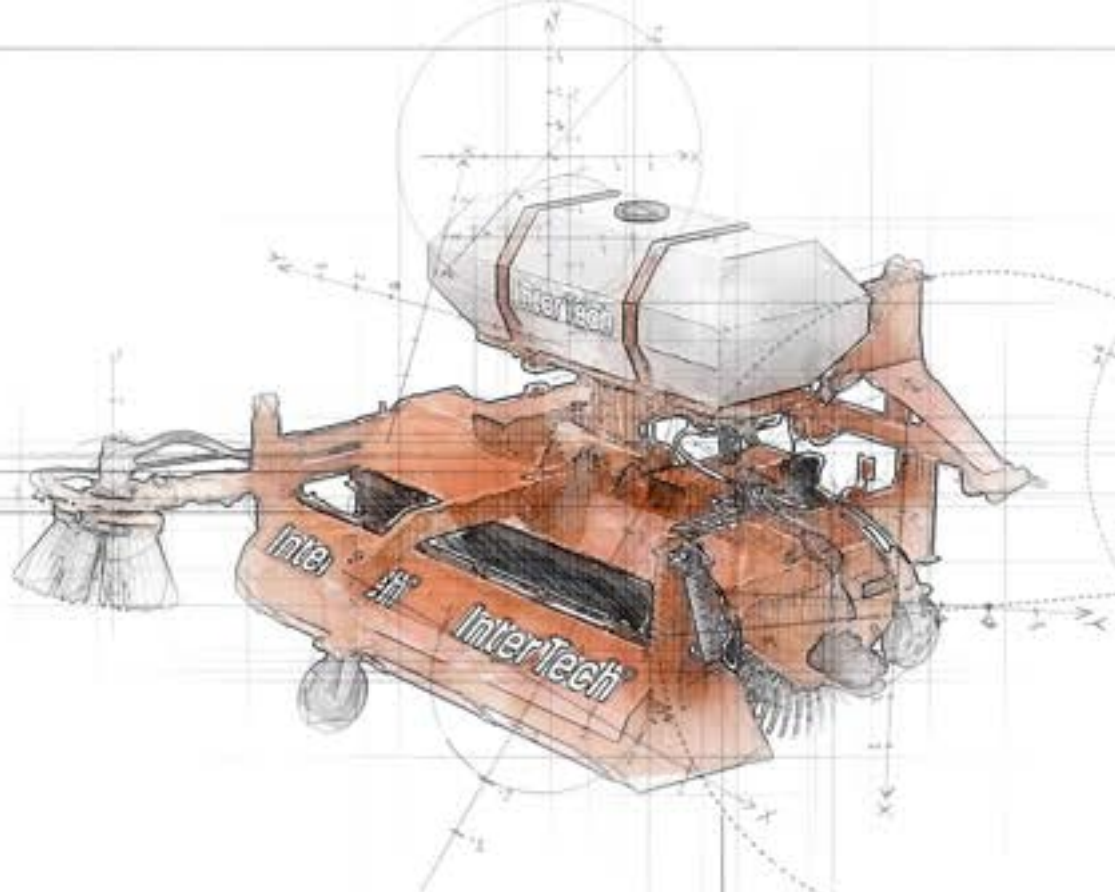

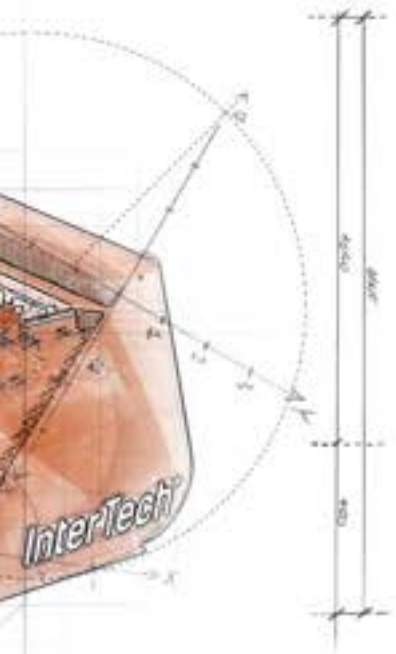

# Orange Line

Distance does not matter. The most important thing is safety.

In autumn and winter, road conditions can be difficult. The weather can be capricious and unpredictable. Comfort and safety can only be provided by reliable machines ready to fulfil their role. Well-thought-out solutions ensure readiness for the challenges of everyday life regardless of the variability of the weather.





# PLOWS

The plow is designed for clearing snow from both paved and unpaved road surfaces. The V-type snow plow is an excellent partner for demanding conditions. Two independently controlled mouldboards allow for precise snow removal even on the most challenging terrain. It adapts perfectly to the uneven terrain thanks to the transverse terrain copying function.

A specially designed blade tilting mechanism protects against unforeseen obstacles. The construction of the plow is durable and at the same time extremely lightweight. The floating suspension ensures constant and even pressure on the ground. It works perfectly with tractors, telescopic loaders, or mini loaders.

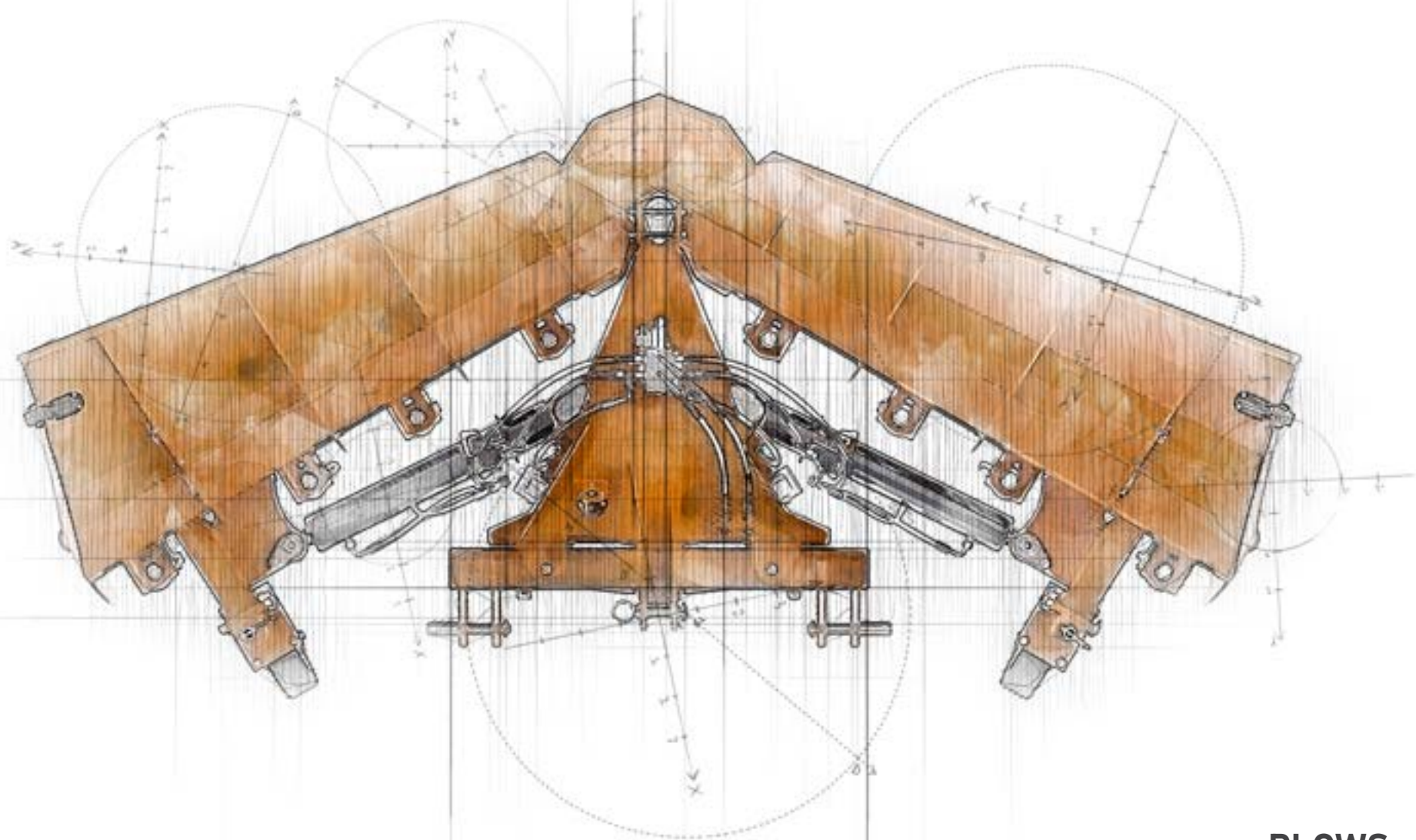

**PLOWS**

**Always ready to serve.**

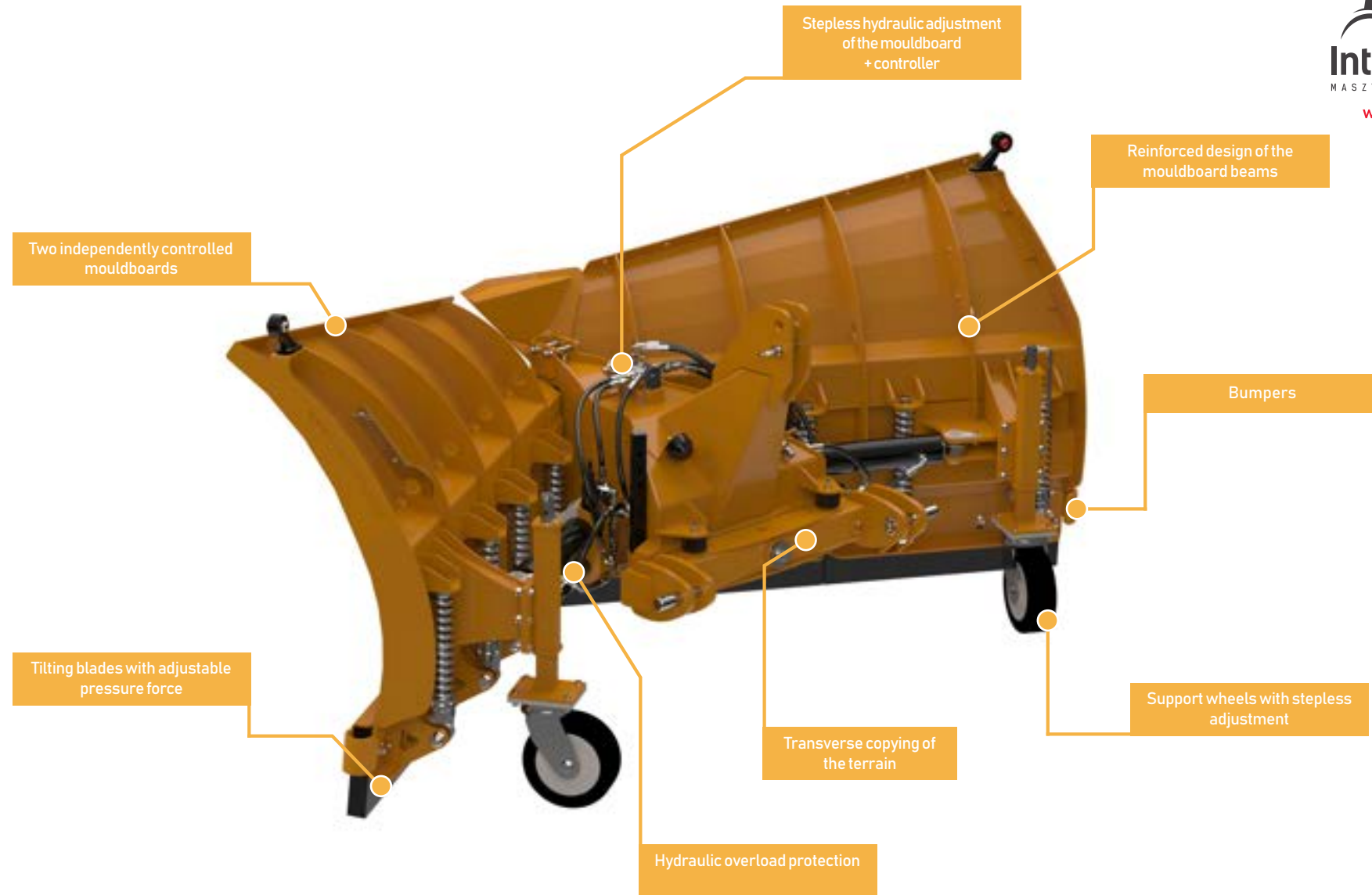

# HYDRAULIC PLOW

## PSSHV HD



MIN. 120 KM



2,85-4 m



1,24-1,28 m

# HYDRAULIC PLOW PSSHV HD

**ORANGE**  
line

Machine no	OPV01	OPV02	OPV03
Width (m)	3,2	3,6	4,0
Minimum working width (m)	2,85	3,25	3,65
Maximum working width (m)	3,2	3,6	4,0
Mouldboard height (m)	1,24	1,26	1,28
Steering angle (°)	30	30	30
Minimum tractor power (HP)	120	120	120
Weight (kg)	810	870	920
Equipment			
TUZ connection cat. II, III	✓	✓	✓
Amortized blade	✓	✓	✓
Two independently controlled mouldboards	✓	✓	✓
Electric connector 12V	✓	✓	✓
Stepless hydraulic adjustment of the mouldboard + controller	✓	✓	✓
Transverse copying of the terrain	✓	✓	✓
Scraper bar (mm) 50	✓	✓	✓
Support wheels with stepless adjustment	✓	✓	✓
Tilting blades with adjustable pressure force	✓	✓	✓
Hydraulic overload protection	✓	✓	✓
Lighting	✓	✓	✓
Additional snow cover (€)	●	●	●
Steel blade (m) (€)	●	●	●
Polyurethane blade (m) (€)	○ ●	○ ●	○ ●
EURO /TUZ connection	—	—	—
Telehandler mount (€)	●	●	●
Skid steer mount (€)	—	—	—
Service package	● ●	● ●	● ●

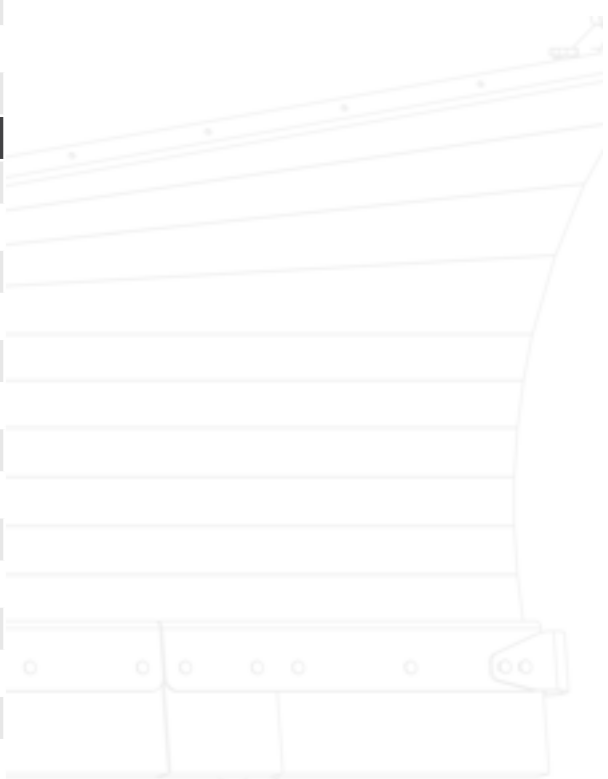

- ✓ Standard equipment
- Optional equipment
- Option not available
- ● Recommended
- ● Especially recommended







## HYDRAULIC PLOW

PSSHV-01



MIN. 80 KM



2,15-4,0 m



1,1 m

# ORANGE

line

## HYDRAULIC PLOW PSSHV-01



Machine no	OPV04	OPV05	OPV06	OPV07
Width (m)	2,5	3,15	3,6	4,0
Minimum working width (m)	2,15	2,70	3,20	3,55
Maximum working width (m)	2,5	3,15	3,6	4,0
Mouldboard height (m)	1,1	1,1	1,1	1,1
Steering angle (°)	30	30	30	30
Minimum tractor power (HP)	80	80	80	80
Weight (kg)	630	690	710	745
Equipment				
EURO or SMS or TUZ cat. II connection	✓	✓	✓	✓
Amortized blade	✓	✓	✓	✓
Two independently controlled mouldboards	✓	✓	✓	✓
Electric connector 12V	✓	✓	✓	✓
Stepless hydraulic adjustment of the mouldboard + controller	✓	✓	✓	✓
Transverse copying of the terrain	✓	✓	✓	✓
Scraper bar (mm) 50	✓	✓	✓	✓
Support wheels / slides	✓	✓	✓	✓
Lighting	✓	✓	✓	✓
Steel blade (m) (€)	●	●	●	●
Polyurethane blade (m) (€)	○ ●	○ ●	○ ●	○ ●
EURO /TUZ connection	● ●	● ●	● ●	● ●
Telehandler mount (€)	●	●	●	●
Skid steer mount (€)	—	—	—	—
Service package	● ●	● ●	● ●	● ●

- ✓ Standard equipment
- Optional equipment
- Option not available
- Recommended
- Especially recommended







## HYDRAULIC PLOW

PSSHV-02



MIN. 50 KM



1,95-2,5 m



0,95 m

## HYDRAULIC PLOW PSSHV-02

Machine no	OPV08	OPV09
Width (m)	2,1	2,5
Minimum working width (m)	1,90	2,20
Maximum working width (m)	2,1	2,5
Mouldboard height (m)	0,95	0,95
Steering angle (°)	29	29
Minimum tractor power (HP)	50	50
Weight (kg)	310	360
Equipment		
EURO or SMS or TUZ cat. II connection	✓	✓
Amortized blade	✓	✓
Two independently controlled mouldboards	✓	✓
Electric connector 12V	✓	✓
Stepless hydraulic adjustment of the mouldboard + controller	✓	✓
Transverse copying of the terrain	✓	✓
Scraper bar (mm) 50	✓	✓
Support wheels / slides	✓	✓
Lighting	✓	✓
Steel blade (m) (€)	●	●
Polyurethane blade (m) (€)	○ ●	○ ●
EURO / TUZ connection	● ●	● ●
Telehandler mount (€)	●	●
Skid steer mount (€)	●	●
Service package	● ●	● ●

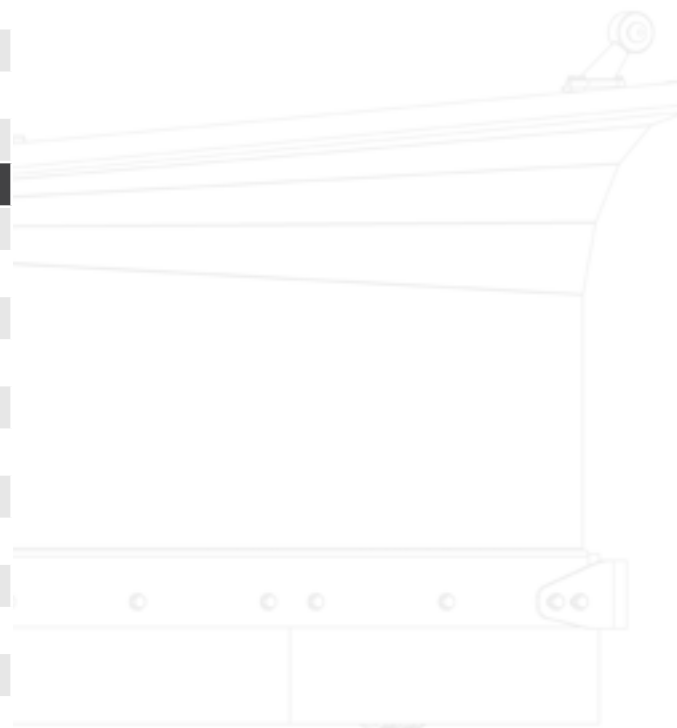

- ✓ Standard equipment
- Optional equipment
- Option not available
- Recommended
- Especially recommended



PSSHV 03



PSSHV 03  
www.ultratech-ago.pl

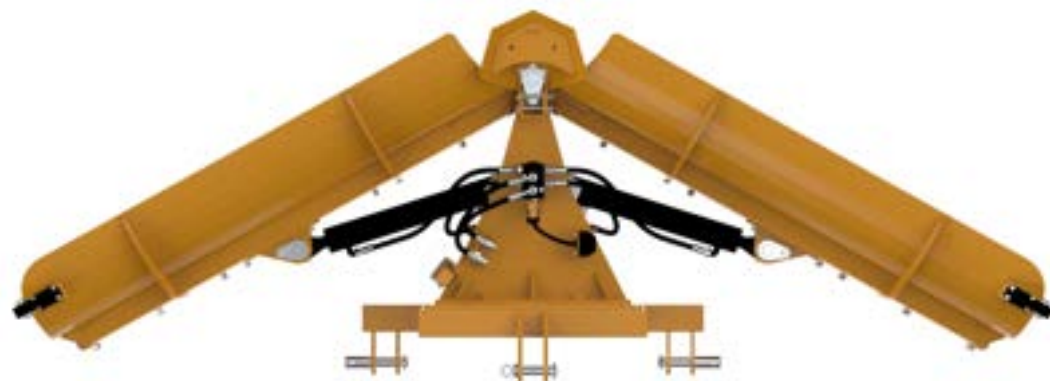

## HYDRAULIC PLOW

PSSHV-03



MIN. 60 KM



1,85-3,0 m



0.9 m

## HYDRAULIC PLOW PSSHV-03

Machine no	OPV10	OPV11	OPV12
Width (m)	2,1	2,6	3,15
Minimum working width (m)	1,85	2,30	2,75
Maximum working width (m)	2,1	2,6	3,0
Mouldboard height (m)	0,9	0,9	0,9
Steering angle (°)	29	29	29
Minimum tractor power (HP)	60	60	60
Weight (kg)	320	370	430
Equipment			
EURO or SMS or TUZ cat. II connection	✓	✓	✓
Two independently controlled mouldboards	✓	✓	✓
Electric connector 12V	✓	✓	✓
Stepless hydraulic adjustment of the mouldboard + controller	✓	✓	✓
Transverse copying of the terrain	✓	✓	✓
Scraper bar (mm) 50	✓	✓	✓
Lighting	✓	✓	✓
Support wheels / slides	—	●	●
Steel blade (m) (€)	●	●	●
Polyurethane blade (m) (€)	○ ●	○ ●	○ ●
EURO /TUZ connection	● ●	● ●	● ●
Telehandler mount (€)	●	●	●
Skid steer mount (€)	●	●	—
Service package	● ●	● ●	● ●

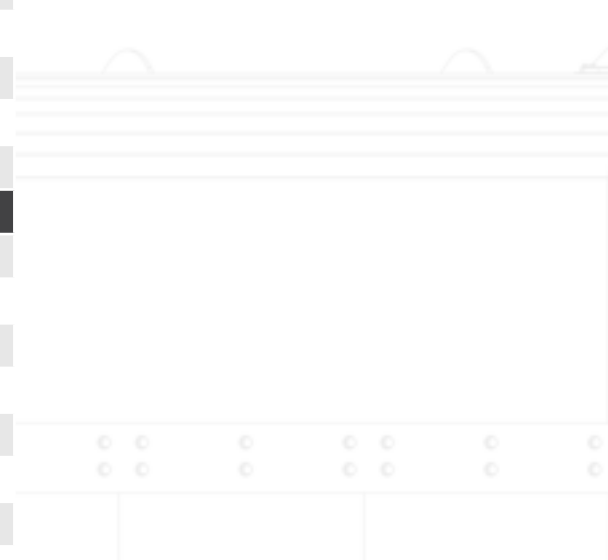

- ✓ Standard equipment
- Optional equipment
- Option not available
- ● Recommended
- ● Especially recommended





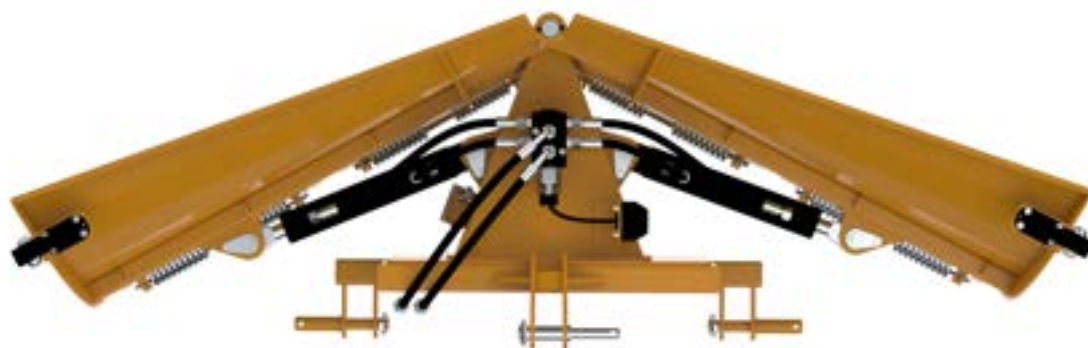

## HYDRAULIC PLOW

PSSHV-04



MIN. 22 KM



1,40-2,24 m



0,7 m

## HYDRAULIC PLOW PSSHV-04

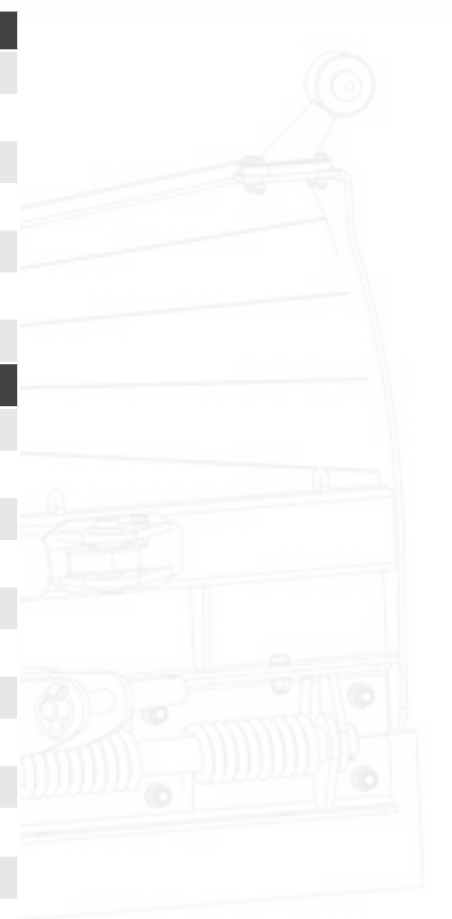

Machine no	OPV13	OPV14	OPV15	OPV16
Width (m)	1,5	1,8	2,0	2,2
Minimum working width (m)	1,40	1,64	1,81	1,96
Maximum working width (m)	1,56	1,84	2,04	2,24
Mouldboard height (m)	0,7	0,7	0,7	0,7
Steering angle (°)	30	30	30	30
Minimum tractor power (HP)	22	22	22	22
Weight (kg)	165	180	190	210
Equipment				
TUZ cat. I, II connection	✓	✓	✓	✓
Two independently controlled mouldboards	✓	✓	✓	✓
Electric connector 12V	✓	✓	✓	✓
Stepless hydraulic adjustment of the mouldboard + controller	✓	✓	✓	✓
Transverse copying of the terrain	✓	✓	✓	✓
Scraper bar (mm) 50	✓	✓	✓	✓
Lighting	✓	✓	✓	✓
Support wheels / slides	—	●	●	●
Steel blade (m) (€)	●	●	●	●
Polyurethane blade (m) (€)	○●	○●	○●	○●
EURO /TUZ connection lub EURO or SMS	●	●	●	●
Telehandler mount (€)	—	—	—	—
Skid steer mount (€)	●●	●●	●●	●●
Service package	●●	●●	●●	●●

- ✓ Standard equipment
- Optional equipment
- Option not available
- Recommended
- Especially recommended

# SIMPLIFIED FLOWERS

The plow with one blade is designed for clearing snow from paved and unpaved road surfaces. Ploughs with a smaller working width are great for clearing snow from narrow roads, sidewalks or paths.

The two-stage adjustment of the working angle, as well as the support wheels allow you to thoroughly clear the working surface. In turn, the scraper bar protects the snow-removing surface from damage. Its sturdy, durable construction guarantees long-lasting use. It works perfectly with tractors, telehandlers or mini-loaders.

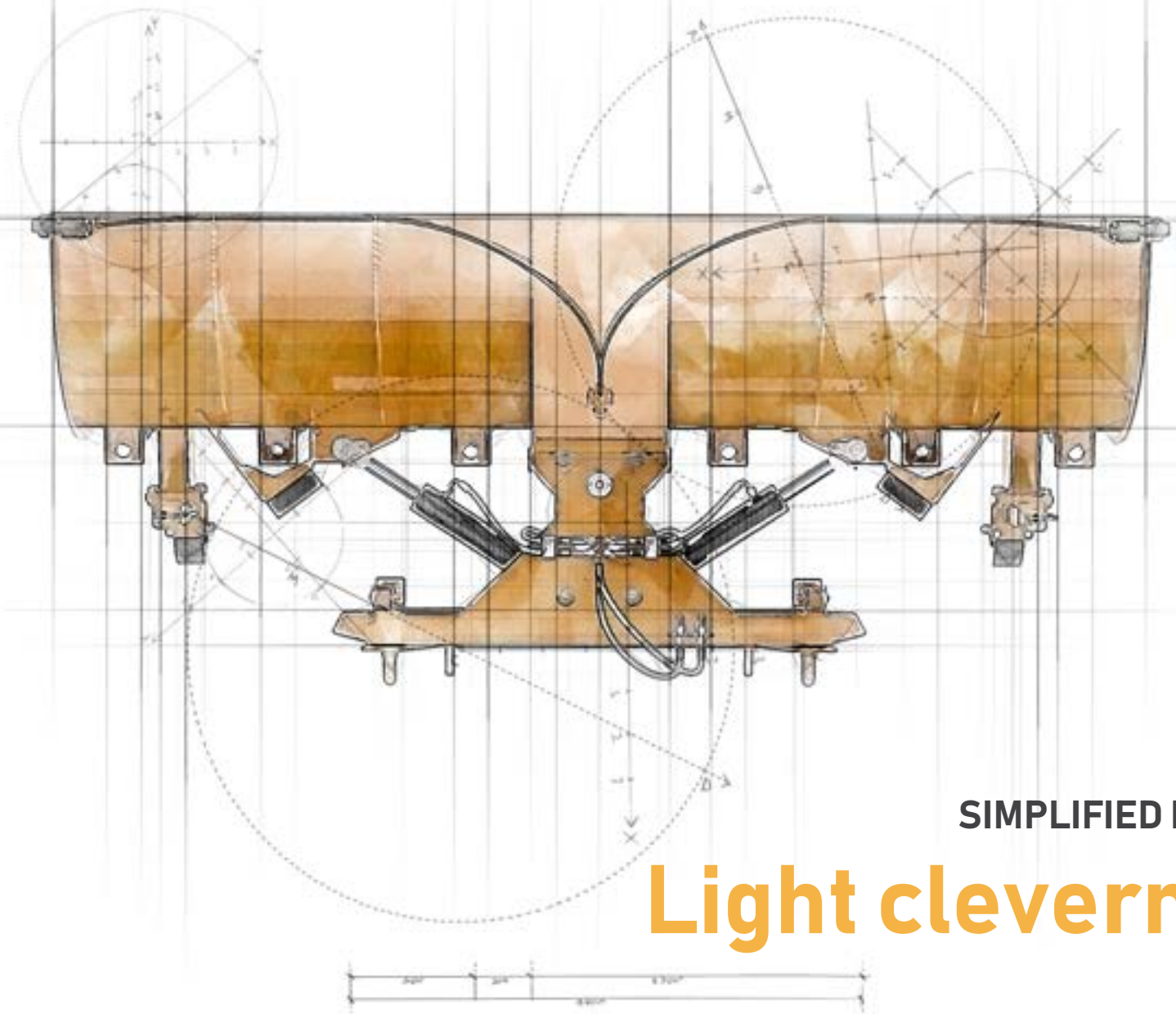

**SIMPLIFIED FLOWERS**

**Light cleverness**

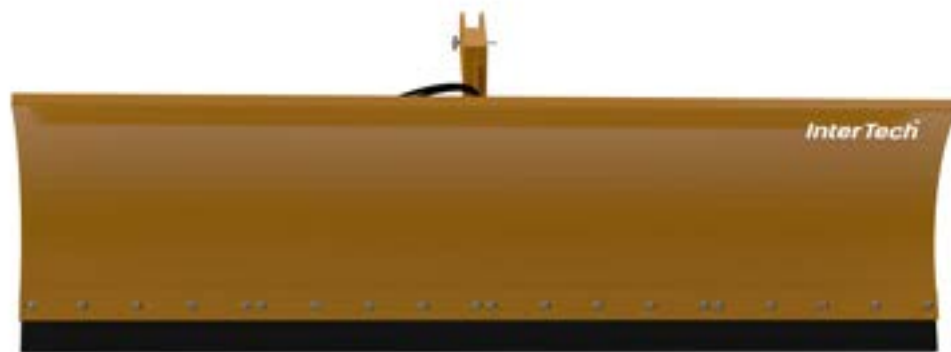

## HYDRAULIC PLOW

### PSSH-02



MIN. 60 KM



2,05-3,0 m



0,83 m

## HYDRAULIC PLOW PSSH-02

Machine no	OP01	OP02	OP03
Width (m)	2,2	2,6	3,0
Minimum working width (m)	2,05	2,45	2,85
Maximum working width (m)	2,2	2,6	3,0
Mouldboard height (m)	0,83	0,83	0,83
Steering angle (°)	23	23	23
Minimum tractor power (HP)	60	60	60
Weight (kg)	315	330	355
Equipment			
EURO or SMS or TUZ cat. II connection	✓	✓	✓
Scraper bar (mm) 50	✓	✓	✓
Lighting	●	●	●
Support wheels / slides	●	●	●
Steel blade (m) (€)	●	●	●
Polyurethane blade (m) (€)	○ ●	○ ●	○ ●
EURO /TUZ connection	● ●	● ●	● ●
Telehandler mount (€)	●	●	●
Skid steer mount (€)	●	●	●
Service package	● ●	● ●	● ●



- ✓ Standard equipment
- Optional equipment
- Option not available
- ● Recommended
- ● Especially recommended



InterTech™





## HYDRAULIC PLOW

### PSSH-03



MIN. 80 KM



2,37-2,95 m



1,06 m

## HYDRAULIC PLOW PSSH-03

Machine no	OP04	OP05
Width (m)	2,65	2,95
Minimum working width (m)	2,37	2,72
Maximum working width (m)	2,65	2,95
Mouldboard height (m)	1,06	1,06
Steering angle (°)	24	24
Minimum tractor power (HP)	80	80
Weight (kg)	640	685
Equipment		
EURO or SMS or TUZ cat. II connection	✓	✓
Amortized blade	✓	✓
Electric connector 12V	✓	✓
Scraper bar (mm) 50	✓	✓
Support wheels / slides	✓	✓
Lighting	✓	✓
Steel blade (m) (€)	●	●
Polyurethane blade (m) (€)	○ ●	○ ●
EURO / TUZ connection	● ●	● ●
Telehandler mount (€)	●	●
Skid steer mount (€)	—	—
Service package	● ●	● ●



- ✓ Standard equipment
- Optional equipment
- Option not available
- Recommended
- Especially recommended





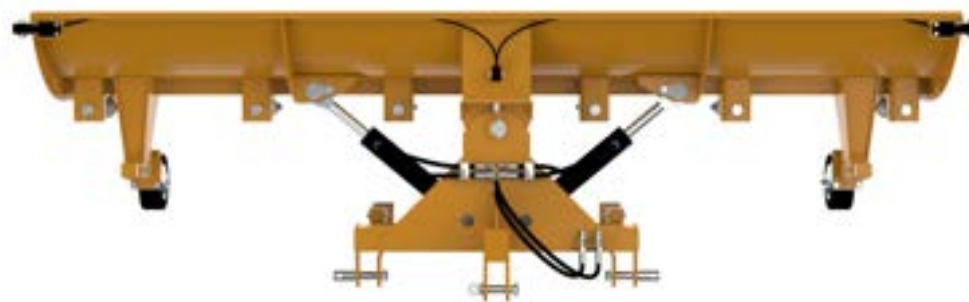
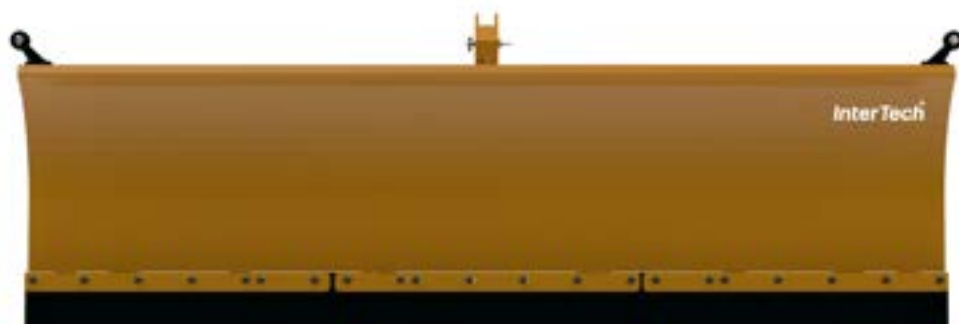

## HYDRAULIC PLOW

PSSH-04



MIN. 60 KM



2,05-3,0 m



0,82 m

## HYDRAULIC PLOW PSSH-04

Machine no	OP06	OP07	OP08
Width (m)	2,2	2,6	3,0
Minimum working width (m)	2,05	2,45	2,85
Maximum working width (m)	2,2	2,6	3,0
Mouldboard height (m)	0,82	0,82	0,82
Steering angle (°)	23	23	23
Minimum tractor power (HP)	60	60	60
Weight (kg)	365	390	420
Equipment			
EURO or SMS or TUZ cat. II connection	✓	✓	✓
Amortized blade	✓	✓	✓
Electric connector 12V	✓	✓	✓
Scraper bar (mm) 50	✓	✓	✓
Support wheels / slides	✓	✓	✓
Lighting	✓	✓	✓
Steel blade (m) (€)	●	●	●
Polyurethane blade (m) (€)	○ ●	○ ●	○ ●
EURO / TUZ connection	● ●	● ●	● ●
Telehandler mount (€)	●	●	●
Skid steer mount (€)	●	●	—
Service package	● ●	● ●	● ●

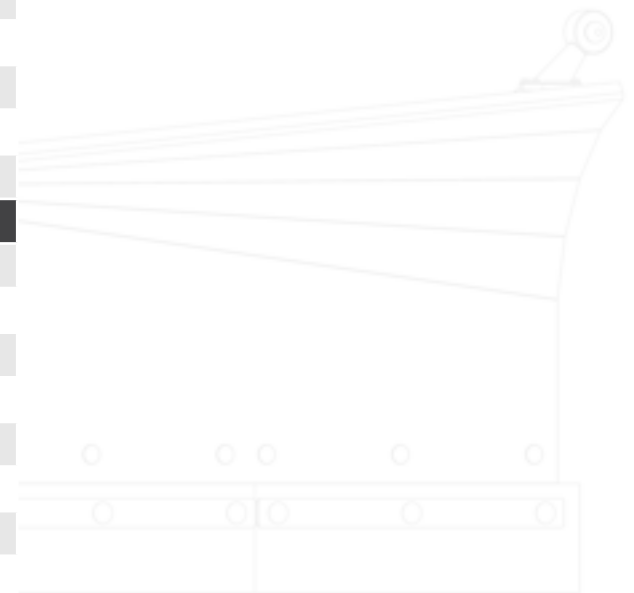

- ✓ Standard equipment
- Optional equipment
- Option not available
- Recommended
- Especially recommended





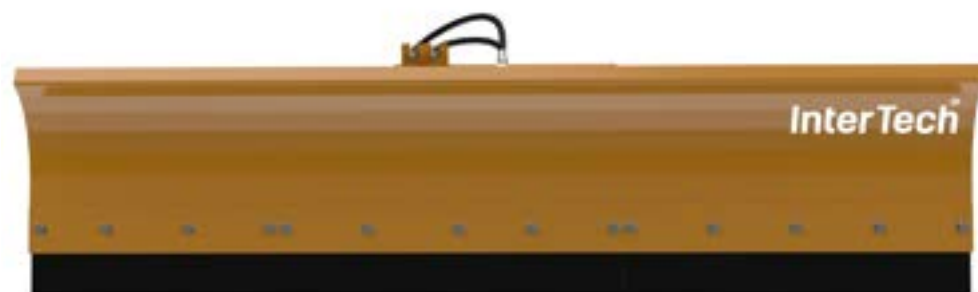

## HYDRAULIC PLOW MINI



MIN. 30 KM



1.82-2.0 m



0,5 m

## HYDRAULIC PLOW MINI

Machine no	OP09
Width (m)	2.0
Minimum working width (m)	1.82
Maximum working width (m)	2.0
Mouldboard height (m)	0.5
Steering angle (°)	25
Minimum tractor power (HP)	30
Weight (kg)	150
<b>Equipment</b>	
Skid steer mount (€)	✓
Scraper bar (mm) 50	✓
Steel blade (m) (€)	●
Polyurethane blade (m) (€)	○ ●
Service package	● ●

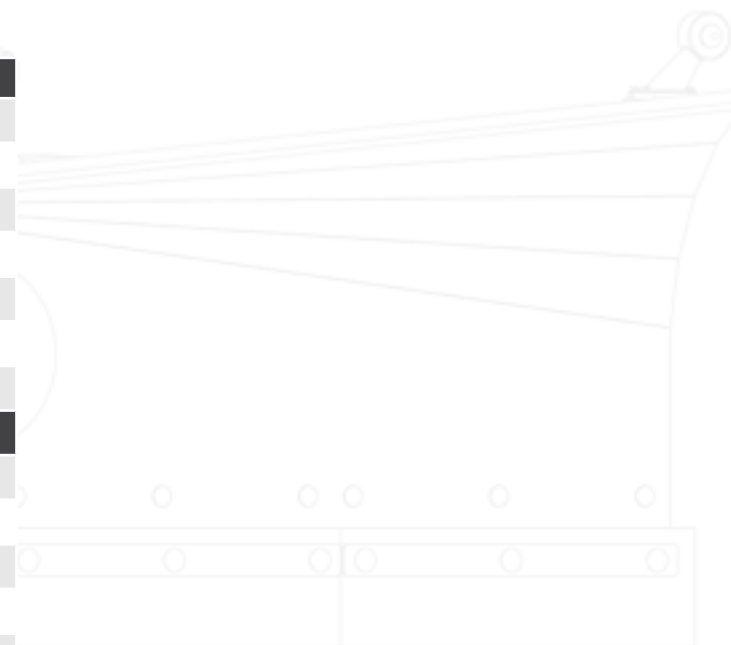

- ✓ Standard equipment
- Optional equipment
- Option not available
- Recommended
- Especially recommended

# SWEEPER

The sweeper is a reliable device for use at any time of the year. The possibility of various configurations means that it will be perfect for spring and summer clean-ups along roads, squares, or sidewalks, as well as during winter when a light snowfall prevents free movement.

The properly constructed suspension system allows the sweeper to move on different planes, which means it copies the terrain excellently. Using a watering system will minimize the risk of dust during work on hot days. Adding a side brush (left or right) will enable thorough cleaning even in the most inaccessible nooks. A protective strip guarantees that the sweeper will not be damaged by stones or other dangerous elements during operation.

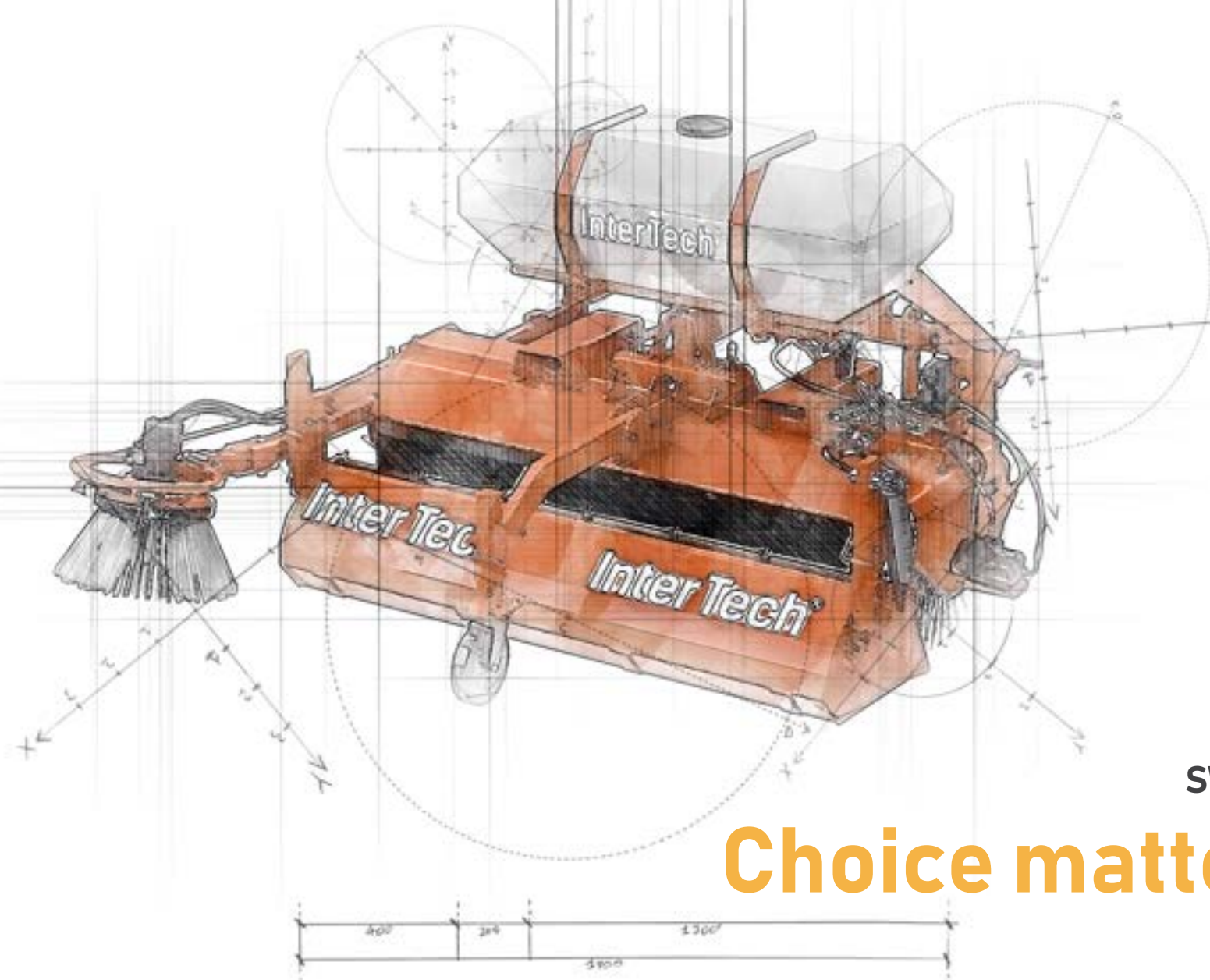

**SWEeper**

**Choice matters.**





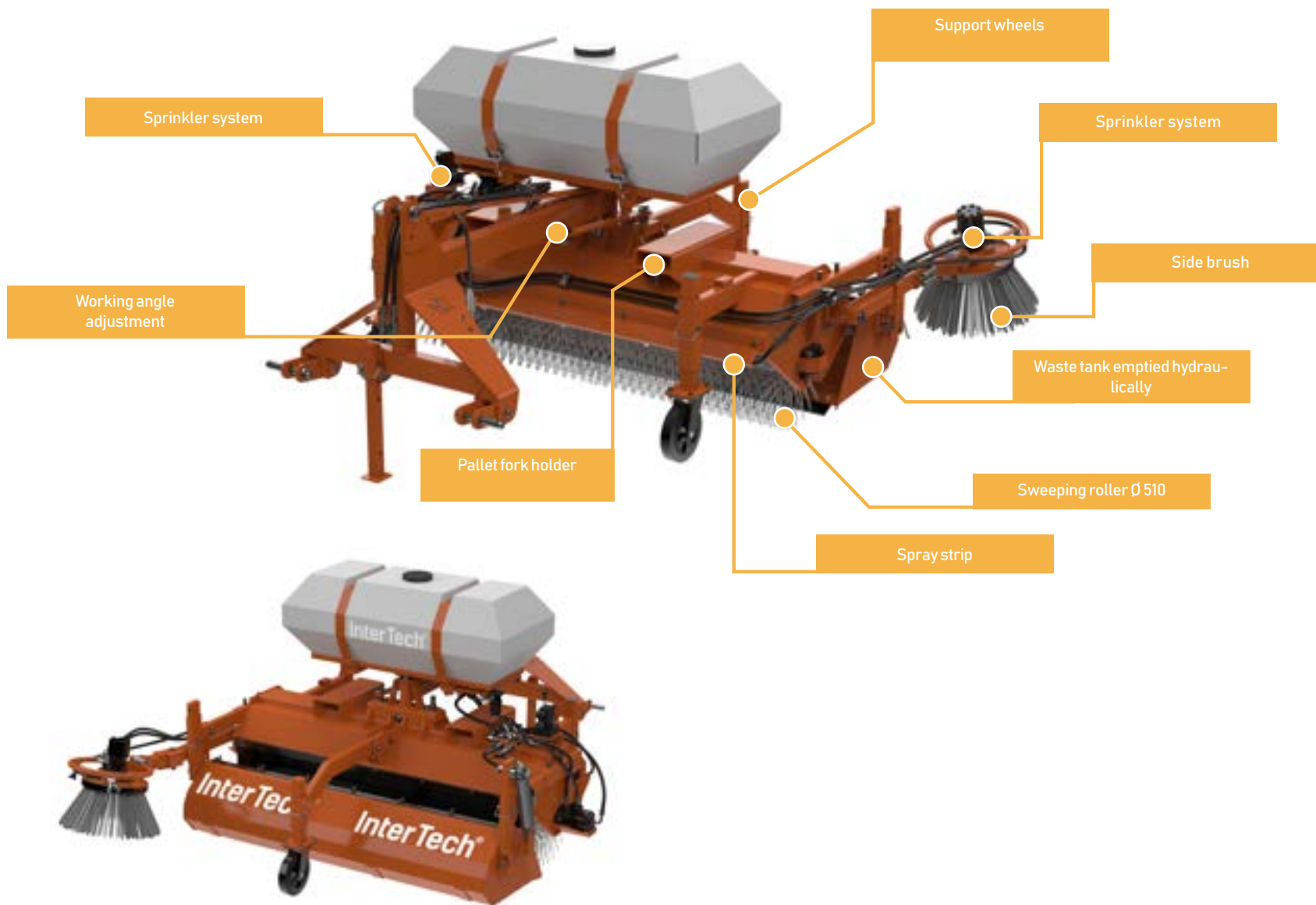

# SWEeper

## SWEEP AQUA



## SWEEPER SWEEP AQUA

Model	Sweep 1.6	Sweep 1.8	Sweep 2.0	Sweep 2.2	Sweep 2.4
Machine no	OZ01	OZ02	OZ03	OZ04	OZ05
Width (m)	1,6	1,8	2,0	2,2	2,4
Waste tank capacity (m3)	0,16	0,18	0,20	0,22	0,24
Minimum tractor power (HP)	30	30	30	30	30
Weight (kg)	340	355	370	385	400
Equipment					
EURO or SMS or TUZ cat. II connection	✓	✓	✓	✓	✓
Transverse copying of the terrain	✓	✓	✓	✓	✓
Support wheels	✓	✓	✓	✓	✓
Waste tank emptied hydraulically	✓	✓	✓	✓	✓
Plastic brush (mm) Ø 510	✓	✓	✓	✓	✓
Mixed brush (mm) Ø 510 (€)	●	●	●	●	●
Wire brush (mm) Ø 510 (€)	●	●	●	●	●
Side brush (left or right) (€)	●●	●●	●●	●●	●●
Hydraulically emptied waste tank	○●	○●	○●	○●	○●
Sprinkler system (€)	○●	○●	○●	○●	○●
Hydraulic adjustment of the working angle (€)	○●	○●	○●	○●	○●
EURO /TUZ connection	○●	○●	○●	○●	○●
Telehandler mount (€)	●	●	●	●	●
Skid steer mount (€)	●	●	—	—	—
Service package	●●	●●	●●	●●	●●

- ✓ Standard equipment
- Optional equipment
- Option not available
- Recommended
- Especially recommended

# BUCKET WITH BRUSH

The bucket with a brush designed for maintaining order in squares or streets will thoroughly clean the area. Thanks to the capacious waste container, the number of trips over the cleaned surface is reduced, thus saving time. The choice of the type of brush means that this device can be used under any conditions. After dismantling the sweeping section, it can be used as a regular bucket.

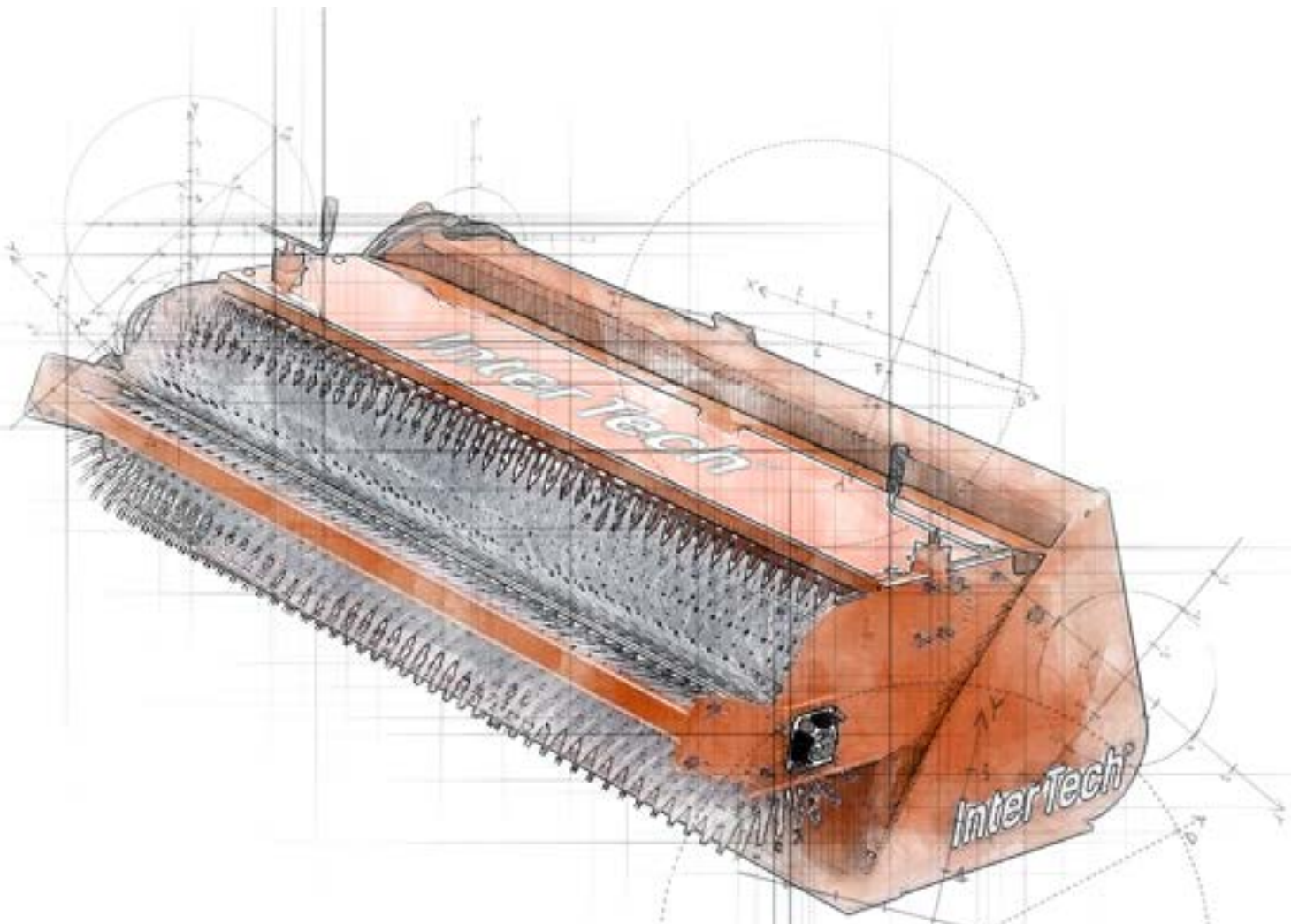

**BUCKET WITH BRUSH**

**Rotating order**



**BUCKET**  
WITH BRUSH



MIN. 50 KM



1,6-2,4 m



370-455 kg

## BUCKET WITH BRUSH

Machine no	OZ06	OZ07	OZ08	OZ09	OZ10
Working width (m)	1,6	1,8	2,0	2,2	2,4
Width (m)	1,9	2,1	2,3	2,5	2,7
Capacity (m <sup>3</sup> )	0,50	0,56	0,62	0,68	0,74
Minimum tractor power (HP)	50	50	50	50	50
Weight (kg)	370	385	410	435	455
Equipment					
EURO or SMS or TUZ cat. II connection	✓	✓	✓	✓	✓
Brush (mm) Ø 510	✓	✓	✓	✓	✓
Plastic brush (mm) Ø 510	✓	✓	✓	✓	✓
Mixed brush (mm) Ø 510 (€)	● ●	● ●	● ●	● ●	● ●
Wire brush (mm) Ø 510 (€)	●	●	●	●	●
Side brush (left or right) (€)	○ ●	○ ●	○ ●	○ ●	○ ●
Full brush cover (€)	●	●	●	●	●
EURO /TUZ connection	● ●	● ●	● ●	● ●	● ●
Telehandler mount (€)	●	●	●	●	●
Skid steer mount (€)	●	●	—	—	—
Service package	● ●	● ●	● ●	● ●	● ●

- ✓ Standard equipment
- Optional equipment
- Option not available
- Recommended
- Especially recommended

# Interdicht



## GUARANTEE

We guarantee a professional service and professional advice. Every customer is important to us.



## ENVIRONMENT

We use renewable energy sources.

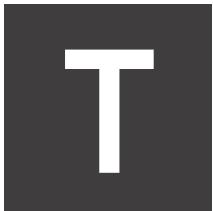

## TRANSPORT



We offer logistical support. Safe delivery of purchased machines.

[www.itlogistic.pl](http://www.itlogistic.pl)



## SAFETY

We build with your safety in mind.

**work safely**



## SERVICE

Helpline service 24/7 Diagnosis, assistance and expert advice in case of any emergencies and questions regarding the use of the machines. We are there when you need us, whatever happens you have our support.

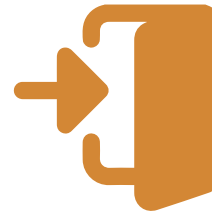

## AVAILABILITY

Online at all times.

enova 365



**work safely**



-  532 777 770
-  Aleja Wojska Polskiego 100,  
18-300 Zambrów
-  [facebook.com/InterTechZambrow](https://facebook.com/InterTechZambrow)
-  [intertech\\_agro](https://instagram.com/intertech_agro)
-  [InterTechAgro](https://www.youtube.com/InterTechAgro)
-  [sekretariat@intertech-agro.pl](mailto:sekretariat@intertech-agro.pl)
-  [www.intertech-agro.pl](http://www.intertech-agro.pl)